

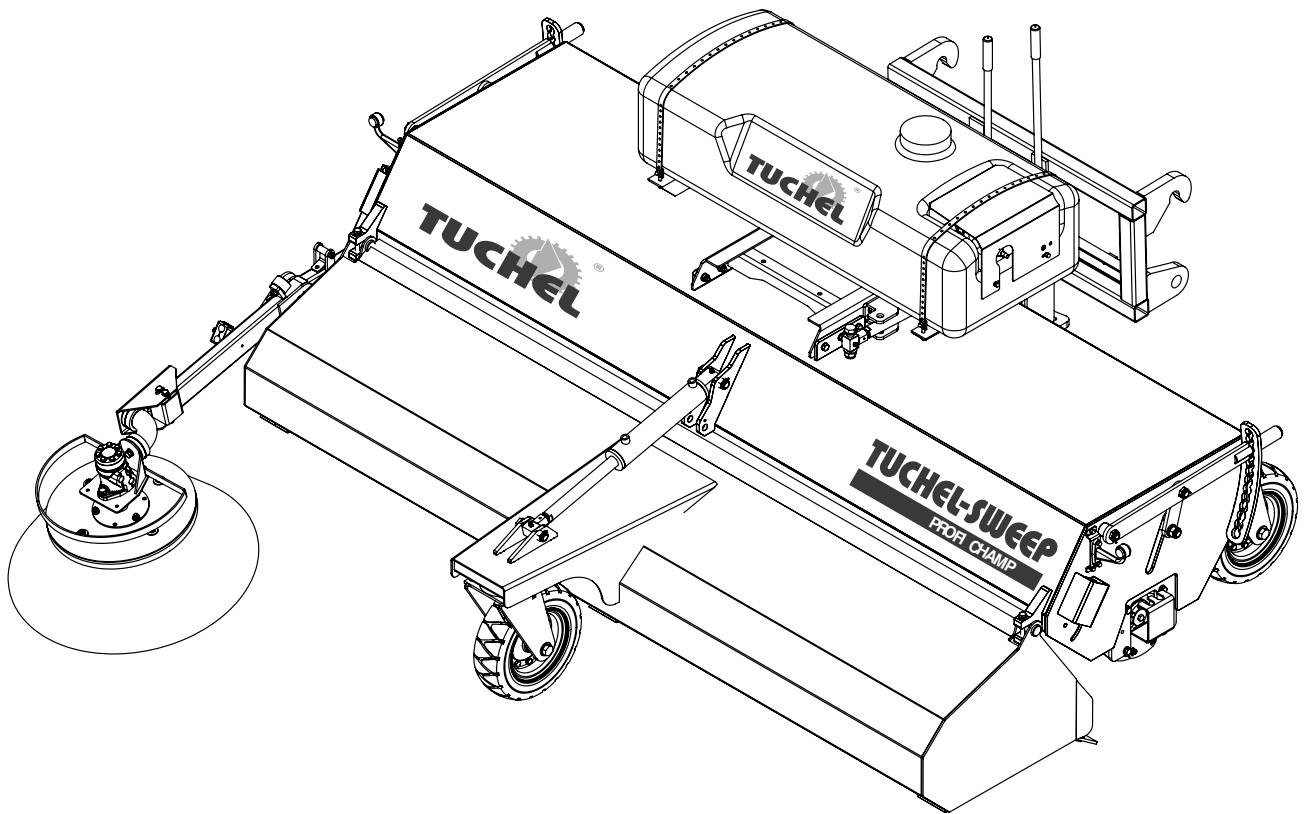

Operating Manual



Profi Champ - **Sweeping Machine**

Preface

Dear Customer,

With the Profi Champ sweeping machine, you have purchased a product that has been manufactured according to the highest quality standards.

This operating manual contains information and notes that are necessary, important and useful for the operational safety and reliability of your Profi Champ sweeping machine as well as for maintaining its value.



Read the operating manual and adhere to the safety notices before start-up.

Its contents familiarise with the use of the machine and its service and maintenance. The manual also helps you to avoid dangers and damage.

We wish you optimum results with your Profi Champ sweeping machine.

Tuchel Maschinenbau GmbH

This operating manual is current as of April 2013

Note

Our continuous efforts towards an improvement of the Profi Champ sweeping machine may lead to changes in detail. The introduction of improvements does not, however, oblige us to carry out these improvements on a Profi Champ sweeping machine already delivered.

Note

If the improvements lead to minor changes, they are not covered by the operating manual. Thus, no claims may be derived from this manual.

Content

Preface	3	3.4 Operation	23
1 General	6	3.4.1 Transport trips	23
1.1 Purpose	6	3.4.2 Start-up.....	23
1.2 Product specifications	6	3.4.3 Side broom adjustment / readjustment.....	24
1.2.1 General	6	3.4.4 Rpm adjustment	25
1.2.2 Manufacturing address.....	6	3.4.5 Emptying the dirt collection vessel	26
1.2.3 Labelling.....	7	3.4.6 Open sweeping.....	26
1.2.4 Declaration of conformity	7	3.4.7 Side adjustment for open sweeping usage	27
1.2.5 Specifications for enquiries and orders.....	7	3.4.8 Readjustment of the sweeping profile	28
1.2.6 Energy consumption.....	8	3.5 Detaching	29
1.2.7 Intended usage	8	3.5.1 Quick change receptacle	30
1.2.8 Technical data sheet	9	3.5.2 Three-point mount.....	30
2 Safety	10	3.5.3 Fork arm receptacle	30
2.1 Labelling of notes in the operating manual	10	4 Service and maintenance	31
2.2 Qualification and training of personnel ...	10	4.1 General.....	31
2.3 Dangers in the case of nonobservance of the safety notices	11	4.2 Replace brush rings	32
2.4 Safety-oriented work	11	4.2.1 Brush shaft, internal motor	32
2.5 Safety notes for the operator / user	11	4.3 Replacing the plate broom.....	34
2.6 Safety notes for carrying out service, inspection and installation work	14	4.4 Replacing the Vulkollan rail	35
2.7 Unauthorised conversion and spare parts manufacturing.....	14	4.5 Water spraying device.....	35
2.8 Modes of operation that are not permitted .	14	4.6 Lubrication plan.....	36
2.9 Warning images on the machine according to ISO 11684	15	4.7 Malfunctions; causes and rectification....	37
3 Profi Champ - Sweeping Machine ..	16	Notes:	38
3.1 Description of the product and accessories .	16		
3.2 Storage.....	18		
3.3 Attachment	19		
3.3.1 Initial attachment.....	20		
3.3.2 Quick change receptacle	20		
3.3.3 SK 3-point linkage	21		
3.3.4 Fork arm receptacle	22		

1 General

1.1 Purpose

The Profi Champ sweeping machine is designed for the adaptation to wheeled loaders and construction vehicles. Because of its robust construction and the various operating widths, this sweeping machine is suitable for permanent use on streets and paths.

The Profi Champ sweeping machine is attached by means of the mechanically or hydraulically operated quick change receptacle of the respective carrier vehicle.

As a basic machine, the Profi Champ is an open sweeping machine and thus suitable for cleaning large, firm surfaces.

The various additional accessories – such as the dirt collection vessel with an integrated 3rd support wheel, the water spraying device for dust suppression, one or two side brooms for close-to-the-border sweeping, a hydraulic side adjustment to ease work, etc. – make it possible to adapt the Profi Champ sweeping machine to the most widely varied working environments.

1.2 Product specifications

1.2.1 General

This operating manual applies to the Profi Champ sweeping machine series.

1.2.2 Manufacturing address

Tuchel Maschinenbau GmbH
Holsterfeld 15
48499 Salzbergen, Germany
Telephone 49 (0) 5971 9675 - 0
Fax 49 (0) 5971 9675 - 30
E-mail: info@tuchel.com
Spare parts: service@tuchel.com

1.2.3 Labelling

This information is found on the type label.

Note



Enter the data of your Profi Champ sweeping machine here to have the details ready at all times.

Model	<input type="text"/>
Serial no.	<input type="text"/>
Year of construction/order no.	<input type="text"/>
Max. oil flow [bar]	<input type="text"/>
Maximum oil flow [l/min]	<input type="text"/>
Net weight [kg]	<input type="text"/>

Note

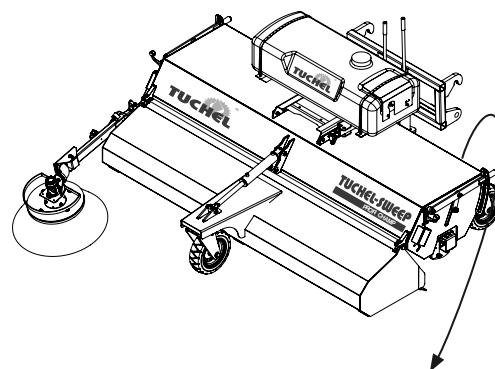
The entire labelling (type label, safety label, etc.) constitutes a certificate and must not be altered or made illegible; replace if damaged or missing.



○ Modell / TYP	<input type="text"/>	 <p>TUCHEL MASCHINENBAU GmbH Holzlarfeld 15 • 48499 Subbergen Tel. 0 59 71 96 75-0 • Fax 0 59 75-30 Internet: http://www.tuchel.com E-Mail: info@tuchel.com</p> 
○ Serien-Nr.	<input type="text"/>	
○ Baujahr / Auftrags-Nr.	<input type="text"/>	
○ max. Betriebsdruck [bar]	<input type="text"/>	
○ max. Ölstrom [kg]	<input type="text"/>	
○ Eigengewicht [kg]	<input type="text"/>	
○ Tragfähigkeit des Flurförderfahrzeugs beachten!		

1.2.4 Declaration of conformity

The compliance of this attachable sweeper with the "basic safety and health requirements" of the machine directive 98/37 EEC entitles it to bear the CE label. During the development of the attachable sweeper, the harmonised European standards DIN EN 292 1+2, DIN EN 982, DIN pr EN 1553, and DIN EN 474 1+2 were also applied. This is documented in the EU declaration of conformity.

1.2.5 Specifications for enquiries and orders

When ordering spare parts or accessories, please specify the type label, serial number and the year of construction of the Profi Champ sweeping machine.

Note

Original accessories /original spare parts and accessories / spare parts authorised by the manufacturer must be used for purposes of safety.

Note

The use of other accessories/spare parts invalidates the liability for the consequences thereof.

1.2.6 Energy consumption

Type of drive: hydraulic
 Type of oil: hydraulic oil according to ISO VG 46 DIN 51524 (e.g., Vitam GF 46 by Aral)

Maximum operating pressure at continuous load: 175 bar

Hydraulic connections: see adjacent table

Note The Profi Champ sweeping machine requires single-acting and/or double-acting control circuits from the carrier vehicle hydraulics. The quantity and type the required control circuits depends on the equipment of the Profi Champ sweeping machine.

Note For further details on energy consumption, refer to Chapter 1.2.8 Technical data

1.2.7 Intended usage

The Profi Champ sweeping machine is a machine that is set in motion via a hydraulic circuit and through the attachment to a suitable carrier vehicle. Its purpose is to clean firm surfaces with normal dirt build-up.

If the machine is used for a purpose different from the one above, we, as the manufacturer, do not take any responsibility for the safety; the risk in this respect rests entirely with the user.

Proper usage includes observance of the operating, maintenance and service conditions that we prescribe as well as relevant specifications.

SA = single acting control circuit DA = double acting control circuit	
• Hydraulic drive	1 x SA
• Hydraulic drive • Dirt collection vessel	1 x DA
• Hydraulic drive • Dirt collection vessel • Side broom	1 x DA
• Hydraulic drive • Dirt collection vessel • Electro-hydr. side adjustment	1 x DA
• Hydraulic drive • Dirt collection vessel • Electro-hydr. side adjustment • Side broom	1 x DA
• Dirt collection vessel • Hydraulic drive • Electro-hydr. side adjustment • Electro-hydr. retractable side broom	1 x DA

1.2.8 Technical data sheet

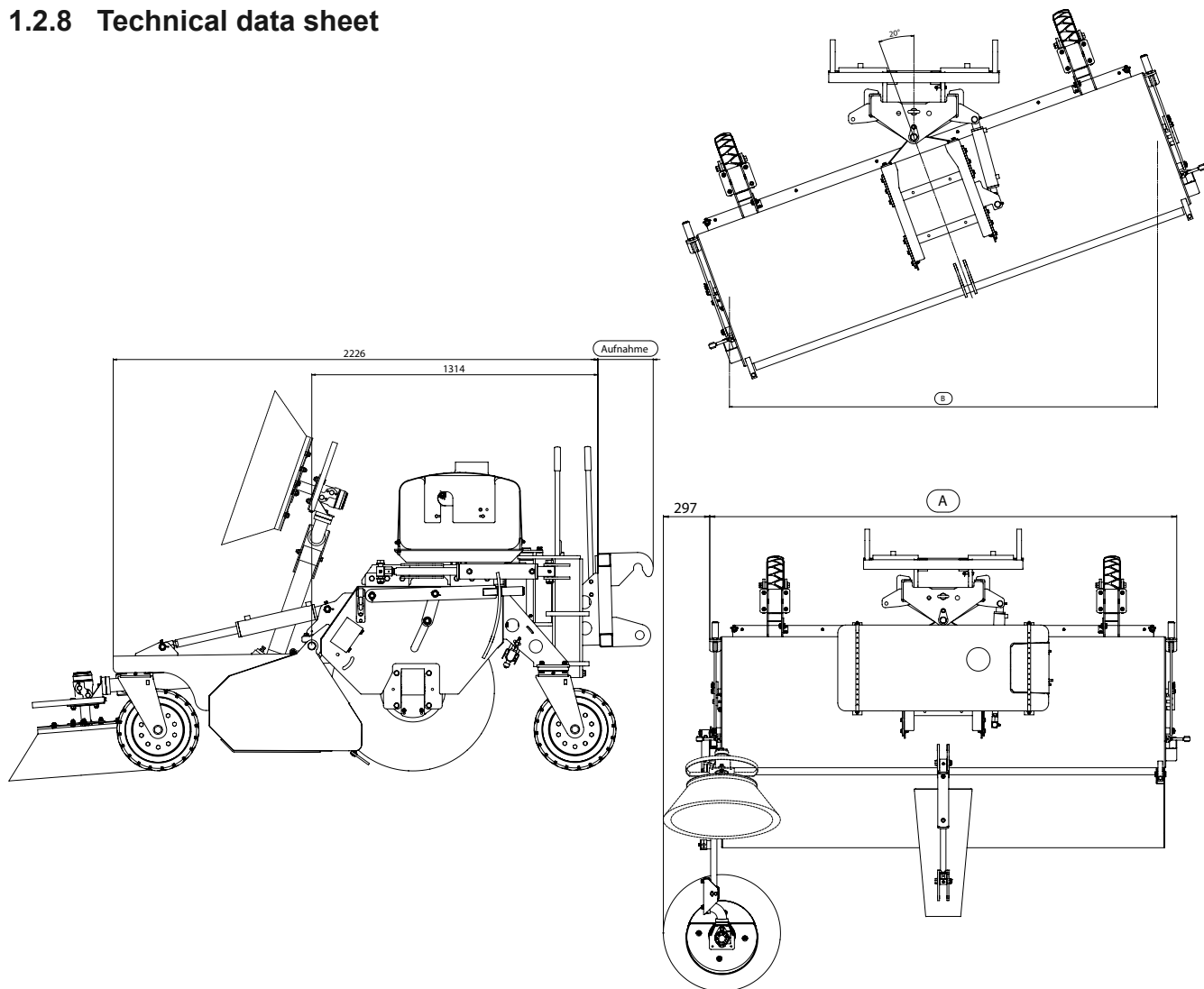

Profi - Champ technical data	Unit	210	240	280
Operating width / A = total width	mm	2100/2361	2400/2870	2800/3195
B = Operating width if positioned at an angle of 20°	mm	1974	2303	2550
Weight of basic machine	kg	398	504	544
Weight of basic machine + collector vessel	kg	577	686	739
Dirt collection vessel volume	l	305	350	400
ØSweeping drum/side broom	mm	750/450	750/450	750/450
Oil quantity required (at 160 bar)	l/min	56		
Maximum operating pressure at continuous load	bar	160		



Use the weights to check compliance with the maximum allowed axle load of the carrier vehicle!

Note

We reserve the right to incorporate changes resulting from further technical development.

Note

Weights are approximate values and vary depending on the machine configuration, receptacle is excluded.

2 Safety

This operating manual contains fundamental instructions that must be observed during the attachment, operation and maintenance. Thus, the personnel must read this operating manual under all circumstances before operation and commissioning. The personnel must always have access to the manual.

Safety notices that must be followed include not only the general safety notices in this section on safety, but also the specific safety notices that are included in other sections.

2.1 Labelling of notices in the operating manual

The safety notices in this operating manual whose non-observance is hazardous for persons are marked with the general danger symbol:

Safety symbol according to DIN ISO 9244



When warning about injuries resulting from squashing



When warning about injuries resulting from cuts



Safety notices whose non-observance create hazards for the machine and its functionality have the word attached.

Attention

Notices are labelled as follows:

Note

Safety signs that are directly attached to the machine must definitely be adhered to and must be kept in a fully legible state.

2.2 Qualification and training of personnel

The Profi Champ sweeping machine must only be used, serviced and maintained by persons that are familiar with the machine and are informed about its dangers. The area of responsibility, competence and the supervision of the personnel must be directed in detail by the operator. If the personnel does not have the necessary knowledge, it must be trained and instructed. Furthermore, the operator must ensure that the personnel fully understands the contents of the operating manual.

Maintenance work that is not described in this operating manual must only be conducted by authorised, qualified workshops.

2.3 Dangers in the case of non-observance of the safety notices

The non-observance of the safety notes results in hazards to both persons as well as to the environment and the machine. Non-observance of the safety notices results in the loss of any claims for damage whatsoever.

In detail, non-observance, **for example**, leads to the following hazards:

- hazards to persons due to non-secured work areas
- failure of important machine functions
- failure of prescribed methods for service and maintenance
- hazards to persons due to mechanical and chemical influences
- hazards to the environment due to leakage of hydraulic oil

2.4 Safety-oriented work

The safety notices listed in this operating manual, current national accident avoidance regulations as well as company-internal regulations governing work, operation, and safety that apply must be followed.

The accident insurance regulations governing safety at work and accident avoidance are binding.

Observe the safety notes of the vehicle manufacturer.

When operating on public roads, the appropriate legal regulations (in the Federal Republic of Germany the StVZO and StVO) must be complied with. Furthermore, the permitted axle loads of the respective vehicle manufacturer must be observed.

2.5 Safety notes for the operator/user

- Before starting work, familiarise yourself with all equipment, operating elements and their functions.
- The clothing of the operators must fit tightly. Avoid loose clothing.
- Observe permitted axle load, gross weight, and transport dimensions.

Hydraulic equipment

- Connect the hydraulic hoses only in the pressure-free state of the vehicle hydraulics.
- Liquids (hydraulic oil) escaping under high pressure penetrate the skin and cause severe injuries. In case of injuries, see a doctor immediately. Danger of infection!
- Hydraulic lines must be replaced no later than after 6 years of usage (including storage time of at most 2 years).
- Regularly check the hydraulic lines and replace them in case of damage and ageing. The replacement lines must comply with the technical requirements of the manufacturer.
- Leakages represent a danger to the environment and must be repaired immediately.
- When searching for leaks, use suitable equipment to avoid injuries.

Start-up

- Depending on the attachment type, the attachment receptacle and its interlocking mechanisms must be checked for tight fit and possible damage prior to start-up. The positioning of the hydraulic hoses must also be checked, as damages occur easily if hydraulic hoses are entangled or squashed.
- During detachment, the supports must be put into their respective position.
- Check the immediate area before starting to drive and before start-up (e.g. for children). Ensure that there is sufficient visibility.
- No person may be present in the work area.
- Only operate the Profi Champ sweeping machine if all protection equipment is attached (receptacle and sweeping machine).

Transport trips

- Check and attach transport equipment - such as illumination, warning equipment and any safety equipment.
- If lighting that is part of the standard carrier vehicle is obscured in the transport position, additional illumination devices must be attached.
- No passengers may be carried on the machine during transport trips.

-
- For transport trips, the hydraulic equipment for operating and lowering the Profi Champ sweeping machine must be secured against accidental operation.
 - Never leave the driving seat while driving.
 - The driving speed must be adapted to suit the respective road and traffic conditions. Avoid sudden turns during uphill and downhill driving and when driving parallel to a slope.
 - Pay attention to the influence of the attached Profi Champ sweeping machine on driving behaviour and steering and braking ability.

Operation

- No passengers may be carried on the machine during operation.
- Never leave the driving seat while driving.
- The driving speed must be adapted to suit the respective road and traffic conditions. Avoid sudden turns during uphill and downhill driving and when driving parallel to a slope.
- Pay attention to the influence of the attached Profi Champ sweeping machine on driving behaviour and steering and braking ability.
- The hydraulic swivel mechanism for swivelling the sweeping machine must only be operated if no persons are present in the area of rotation.

Deinstallation

- After switching off the device there is danger due to the continued movement of the centrifugal mass. Do not approach the machine during this time period. Wait until it has come to a complete standstill.
- Before leaving the carrier vehicle, lower the sweeping machine to the ground. Pull the ignition key and secure the carrier vehicle against unintended restart and movement!
- During deinstallation, the supports must be put into their respective position.

2.6 Safety notes for carrying out service, inspection and installation work

The operator must ensure that all service, inspection and assembly work is carried out by authorised and qualified personnel that has sufficiently informed itself through detailed study of the operating manual.

Work on the machine must, in principle, only be performed while at a standstill. The machine's halting procedure described in the operating manual must absolutely be observed.

When carrying out maintenance on the lifted device, always secure it with suitable supports.

Use suitable tools and gloves when exchanging the sweeping drum and sweeping rail.

Lawfully dispose of oil and grease.

Directly after finishing work, all protection equipment must be reattached.

Before restarting, the points listed in the sections on start-up must be adhered to.

2.7 Unauthorised conversion and spare parts manufacturing

Conversion of or changes to the machine are only permitted after consultation with the manufacturer. Original spare parts and accessories authorised by the manufacturer provide safety. The use of other parts invalidates the liability for the consequences thereof.

2.8 Modes of operation that are not permitted

The operational safety of the machine is only guaranteed if used as intended according to the operating manual (see Chapter 1). The limits specified in the data sheets must not be exceeded under any circumstances.

2.9 Warning images on the machine according to ISO 11684

Read the operating manual and adhere to the safety notices before start-up.

Article no 40000340

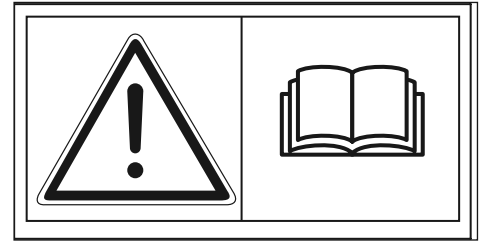

Never reach into the squashing hazard area as long as parts may move.

Article no 40000338

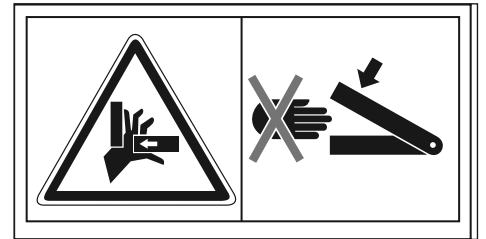

Do not touch any moving machine parts. Wait until they have come to a complete standstill.

Article no 40000341



When lowering the Profi Champ sweeping machine, keep sufficient distance.

Article no 40000342

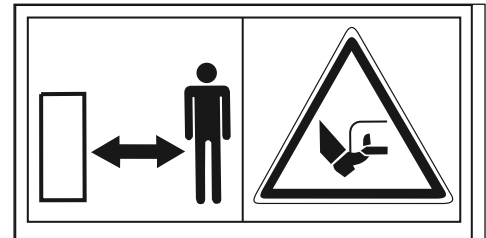

Do not stand in the rotation area during operation.

Article no 40000343

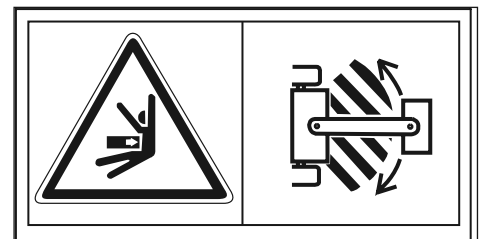

Note

Keep all labels clean at all times. Missing or damaged labels must be replaced.

3 Profi Champ - Sweeping Machine

3.1 Description of the product and accessories

The Profi Champ sweeping machine is designed for both pickup and open sweeping usage. The machine is converted to the open sweeping mode without deinstallation of the dirt collection vessel.

The frame is made of a robust and torsion-free welded construction.

The sweeping drum is suspended freely in the frame using a lever system. The brushes are adjusted by means of a raster bar. Through lever action, the sweeping drum can be readjusted as needed via the raster lever, thus ensuring consistently good sweeping results.

An internal, high-powered hydraulic motor, equipped with a collision protector, directly drives the sweeping drum. The revolution speed of the sweeping drum depends on the oil flow and on the equipment of the carrier vehicle.

The sweeping drum standard equipment includes Beeline brush rings made from 100% PP. The brush rings are 750 mm in diameter.

The dirt collection vessel is opened and closed via the actuation of one hydraulic cylinder. Actuation is initiated from the carrier vehicle. The wear-resistant Vulkollan rail is connected to the lower edge of the dirt collection vessel along its entire length to guide the lower collection vessel edge evenly over the ground without causing any damage.

The Profi Champ sweeping machine is equipped with a direct attachment option that matches the carrier vehicle. By means of direct mounting, the attachment version (quick-change receptacle or three-point mount) is connected with a support-roll carrier to the engine frame.

The support roll carrier of the attachment version provides swaying and levelling compensation in the roller well guide, even on uneven ground.

Using the mechanical, electro-hydraulic or hydraulic side adjustment, the Profi Champ sweeping machine can be rotated by 20° to the right or to the left.

Accessories

- **Water spraying device**

- For dust suppression, with a 200 l water tank and a 12 V (24 V) dry-running pump.
- For dust suppression, with 2 x 200 l water tanks and two 12 V (24 V) dry-running pumps.

- **Hydr. side adjustment**

Tilting of the Profi Champ sweeping machine with hydraulic cylinders. A double-acting hydraulic control circuit is necessary on the carrier vehicle.

- **Electro.-hydr. side adjustment**

Tilting of the Profi Champ sweeping machine with hydraulic cylinders. A double-acting hydraulic control circuit is necessary on the carrier vehicle.

- **Hydr. side broom**

close-to-the-border sweeping with rpm regulation.

- **StVZO (German vehicle licensing regulations) approved equipment,**

consisting of **warning flags** and **contour illumination**. According to StVZO stipulations, both are prescribed and must be used for travelling on public roads.

- **Dirt collection vessel**

with integrated 3rd support wheels, hydraulic drainage is handled through 1 cylinder with tap, for open sweeping use (deinstallation of the collector vessel is unnecessary).

- **High-level filling flap**

for extending the filling volume in the dirt collection vessel (approx. +30%).

3.2 Storage

Note Chapter 3.5 Deinstallation must be accomplished before this chapter.

 Park sweeping machine on a firm and level surface in a dry, clean place.

Attention Accident hazard! Ensure a secure standing of the Prof Champ sweeping machine.

- Close the taps on the side broom (1) and for the hydraulic cylinder (drainage) (1.1).
- Support wheels (2) must be pointed toward to the rear.

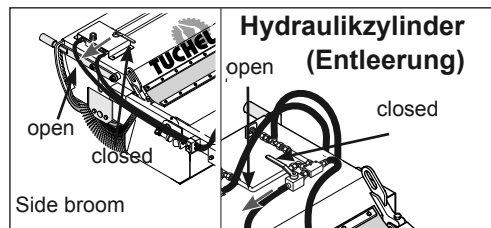

Take the ground pressure off the sweeping drum

- Consecutively pull the handles (3) of the raster lever system on both sides of the machine and put the levers in the adjustment raster in the top position.

Attention Take the sweeping drum's net weight into account when adjusting the levers!

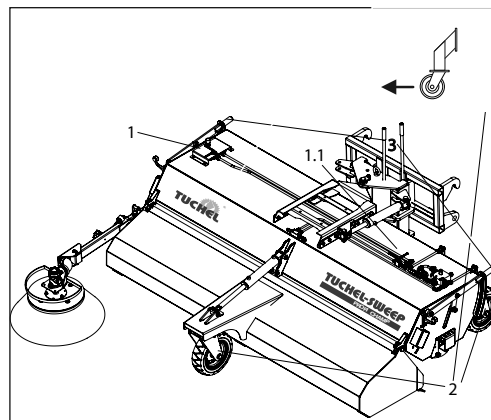

Profi Champ sweeping machine without collector vessel

- For the open sweeping machine, shift the two supports to the ground and secure them.

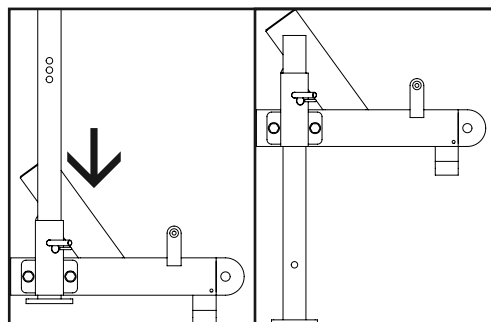

Swing the side broom away from the work area

- Move side broom from position A to position B.
- Lever (4) locks the side broom through the locking bar (5).

 The lever (4) must be completely engaged (5).

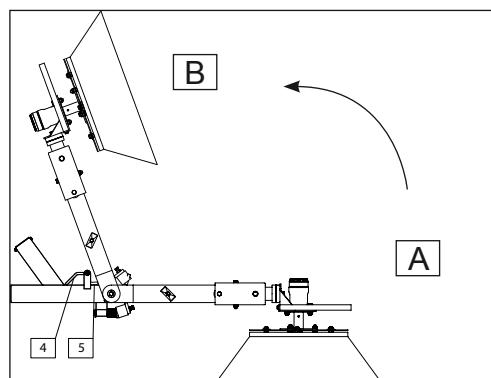

Water spraying device

- Draining the water tank (6). Open the drainage bolt (7) (bottom of tank).
- If there is danger of frosts, activate the pump of the water spraying device for 10 to 15 sec. until no more residual water remains in the hoses.

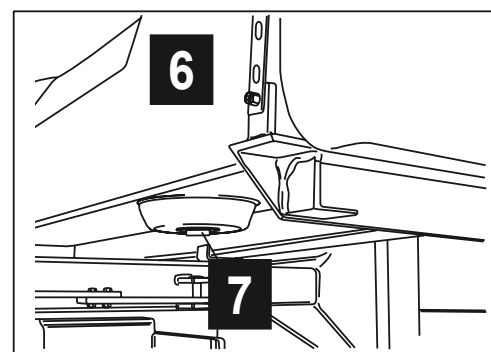



Accident hazard!

Hydraulic hoses and the electrical line are a tripping hazard on the ground. Place them on top of the Profi Champ sweeping machine.



Close the hydraulic connector with the dust cap.

- If necessary, clean the sweeping machine thoroughly. Dirt attracts humidity and leads to the formation of rust.
- Thoroughly grease the Profi Champ sweeping machine.
- If necessary, repair paint damage.

3.3 Attachment



The Profi Champ sweeping machine must be attached to the intended carrier vehicle using the supplied attachment device.



The attachment version itself must not be changed or modified.



The permitted support loads, axle relief, axle loads, gross weight and transport dimensions must be taken from the manufacturer's information about the carrier vehicle and must be checked before start-up.



If a ballast weight is required, attach it as prescribed to the intended attachment points of the carrier vehicle before attaching the sweeping machine.



During attachment, special caution must be exercised.



Follow the operating manual of the carrier vehicle!



Carry out maintenance, repair work and modifications on the Profi Champ sweeping machine only if the hydraulic drive is switched off and hydraulic connections are disconnected. Secure the carrier vehicle against unintended start-up and movement!



Verify the correct attachment and its safeguards. The positioning of the hydraulic hoses and the electrical connection line must also be checked, as damage occurs easily if they are entangled or squashed.

3.3.1 Initial attachment



During the initial attachment of the Profi Champ sweeping machine with water spraying device or illumination system, the cabinet is to be mounted at a suitable position in the carrier vehicle.

- Connect cable (3) to the battery (---).
- Connect cable (4) to the parking light terminal.
- Socket (5) for the electric connection line of the Profi Champ sweeping machine.
- (1) Fuse.
- (2) Off - On switch.

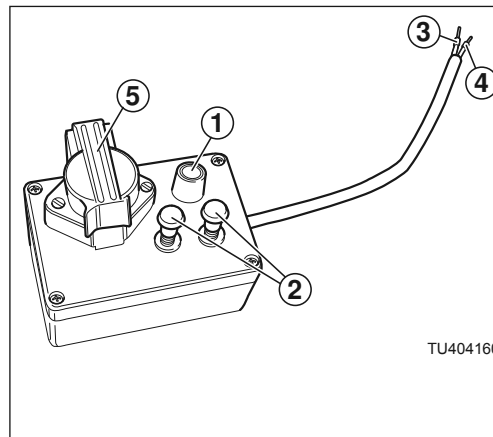

3.3.2 Quick change receptacle



The safety instructions from Chapter 3.3 apply.



Only perform work on the sweeping machine with the engine switched off and the hydraulics depressurised. Pull the ignition key and secure the carrier vehicle against unintended start-up and movement.

Note

Check the receptacle for soiling. Clean if necessary.

- Drive the carrier vehicle to within 300 mm of the Profi Champ sweeping machine.
- Lower the receptacle bolt of the carrier vehicle until below the receptacle openings (1) of the Profi Champ sweeping machine.
- Approach with the carrier vehicle and raise the lifting gear.
- Insert the locking bolts into the drill holes (2).

Attention

Check the receptacle bolt and the locking bolts for proper seating.

- Connect the hydraulic lines according to the instructions of the vehicle manufacturer.
- Connect the electrical connection line for the water spraying device or illumination system at the cabinet in the carrier vehicle.
- Lift the sweeping machine and carry out a functionality check.

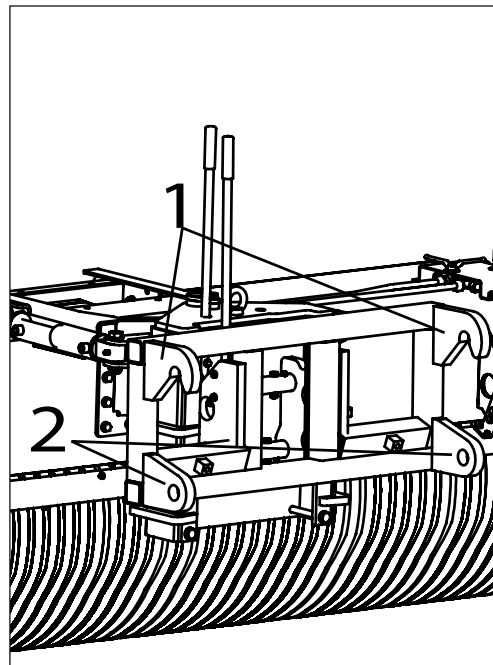

3.3.3 3-point linkage



The safety instructions from Chapter 3.3 apply.



Only perform work on the sweeping machine with the engine switched off and the hydraulics de-pressurised. Pull the ignition key and secure the carrier vehicle against unintended start-up and movement.

Note

Check the 3-point linkage for soiling. Clean if necessary.

- Drive the carrier vehicle to within 300 mm of the Profi Champ sweeping machine.
- Fasten bolt diameter (1) or (2) according to the attachment category of the vehicle manufacturer and secure with spring plug (3).
- Hook the upper hook and secure according to the specifications of the vehicle manufacturer.

Note

The upper hook is to be set so that the attachment receptacle is perpendicular to the ground.

Attention

Verify the correct seating of the attachment receptacle.

- Connect the hydraulic lines according to the instructions of the vehicle manufacturer.
- Connect the electrical connection line for the water spraying device or illumination system at the cabinet in the carrier vehicle.
- Lift the sweeping machine and carry out a functionality check.

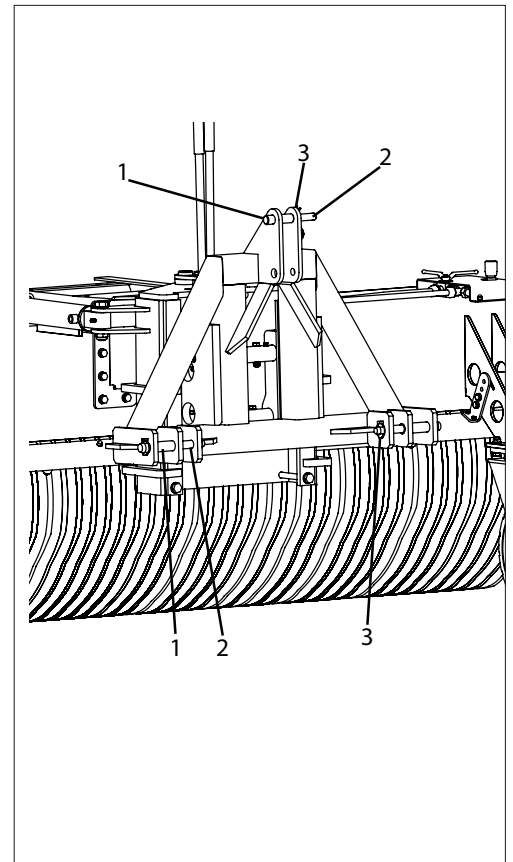

3.3.4 Fork arm receptacle



The safety instructions from Chapter 3.3 apply.

Note

Check fork arm receptacle and fork arms for soiling and clean if necessary.

- Adjust the distance (2) of the fork arms on the carrier vehicle before they are driven in!
- Locking hooks must point downward (1).
- Drive the fork arms into the receptacle (3).
- Shift the locking hooks into place (perform steps (arrow) 4 - 7).

Attention

The lever clicks into place in the drill hole.

- Adjust the distance (8) between arms and lock by shifting the screw connection (9).
- The fork arm receptacle must be additionally secured with a chain (9).
- Guide the chain tightly around the slide carriage of the carrier vehicle and secure with the spring hook (10).

Attention

Chain must not come into contact with the guides of the lifting gear.

Note

Check for correct locking of the locking bracket behind the fork arms. Ensure a tight fit of the chain.

- Connect the hydraulic lines according to the instructions of the vehicle manufacturer.
- Connect the electrical connection line for the water spraying device or illumination system at the cabinet in the carrier vehicle.
- Lift the sweeping machine and carry out a functionality check.

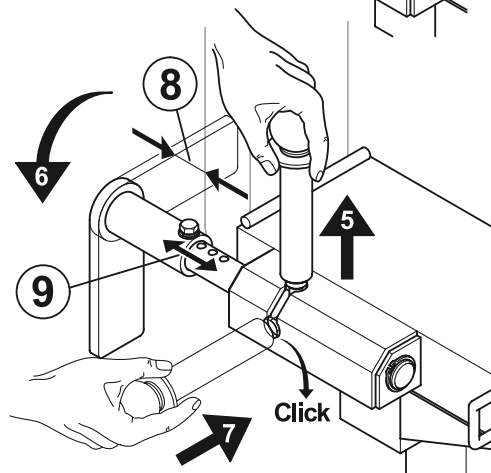
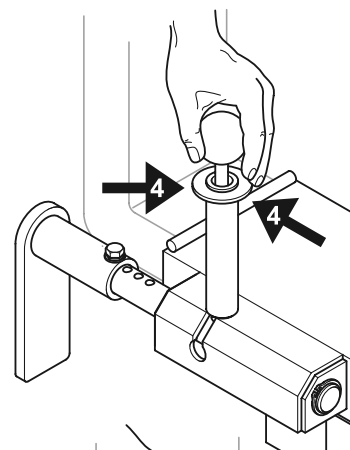
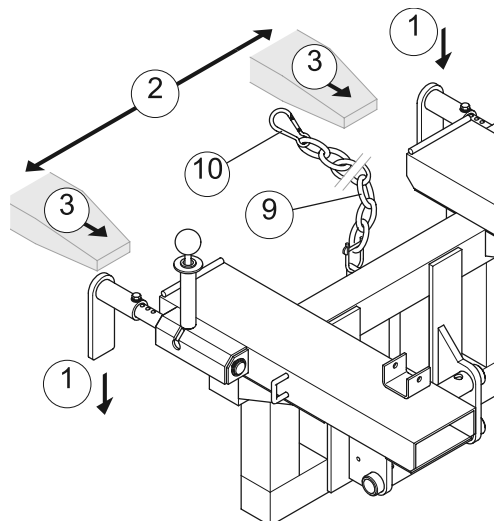

3.4 Operation



First read this chapter and 3.3, then attach the Profi Champ sweeping machine.

3.4.1 Transport trips



Observe the safety instructions from Chapter 3.3.

Note

- Make transport trips only with empty dirt collection vessel.

- Close tap (see Chapter 3.2).
- Put the machine in an upright position (see Chapter 3.4.7).
- Tilt the side broom upwards and secure it (see Chapter 3.2).

Transport trips with attached sweeping machine

Attention

Lift sweeping machine and secure the operating levers for the Profi Champ sweeping machine in the carrier vehicle against unintentional operation.

3.4.2 Start-up



The safety instructions from Chapter 3.3 apply.

- For the open sweeping Profi Champ sweeping machine, shift the two supports upwards and secure them.
- Open the tap of the hydraulic cylinder of the collector vessel emptying mechanism and side broom.
- The maximum driving and sweeping speed is 6 km/h.
- When operating the sweeping machine, a sweeping profile of 6 to 10 cm appears. (See Chapter 3.4.8 for adjustment of the sweeping profile).
- Route the hydraulic hoses and electrical wiring so that there are no pinch points or risk of crushing. (see Chapter 3.3 Initial attachment).

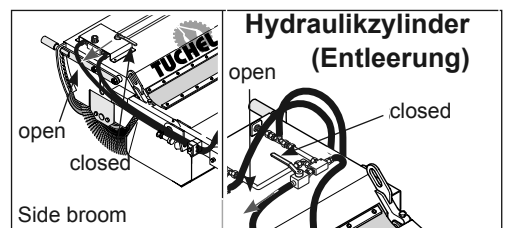
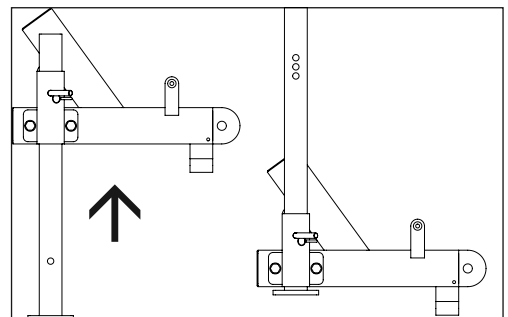
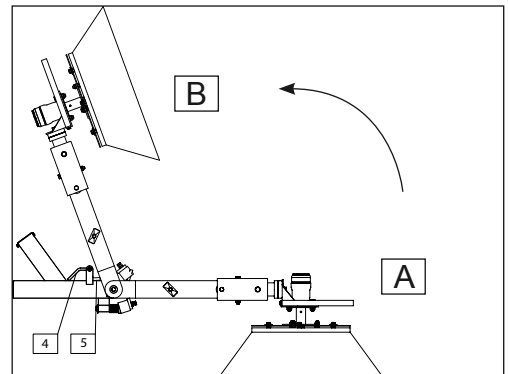
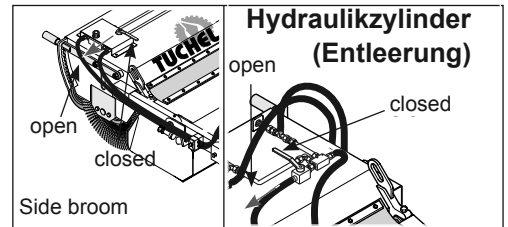

Swing the side broom into the operating position

- Pull the lever (6) out of the catch (7), then swing the side broom from B to A (proceed as described in the adjacent depiction).



Take the side broom's net weight into account.

- Open the tap of the side broom on the sweeping machine roof (see Page 19).
- See Chapter 3.4.3 for adjustment of the sweeping profile of the side broom.

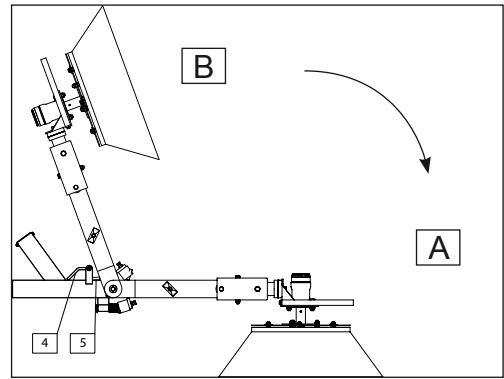

Position of sweeping machine during operation in front of the carrier vehicle

- Lower the sweeping machine until the two (or four) castor wheels (1) touch the ground
- The receptacle structure must be perpendicular to the ground. (receptacle in the roller guide, perpendicular to the ground.)
- Raise or lower the equipment carrier of the vehicle until the attachment support (2) with the support roll carrier is positioned in the centre of the roller guide (3). Height indicator with the green caps (4) are at the same height (=0).
- Now check again that the height indicator of the receptacle and the height indicator of the swivel element are at the same angle (0°) in relation to each other (can be better recognised from the side of the sweeping machine); tilt the equipment carrier in or out as needed.

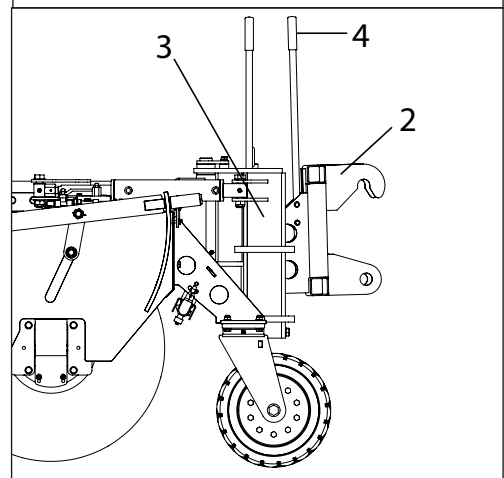
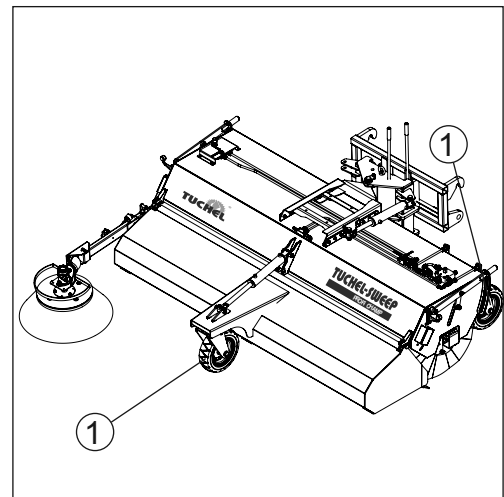

3.4.3 Side broom adjustment / readjustment



The safety instructions from Chapter 3.3 apply.

Attention For the adjustment, take the side broom's net weight into account.

Side broom position

- The extension arm (5) lies on top of the bolt (6) if the sweeping machine is located 3-6 cm above the ground.
- **Readjustment possibility:** Remove splint pin (7), pull out bolt (6) and remove individual spacer washers (8). This way the side broom can be moved downward.

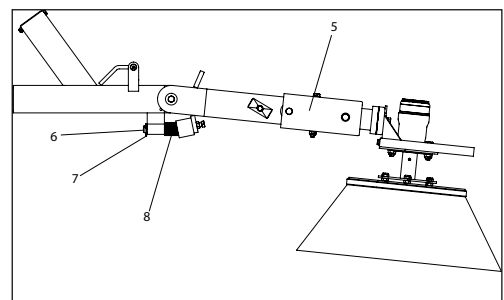

Adjust operating width

- Loosen screw connection (6) and adjust the side broom in the area of the long hole.
- Adjust the screw connection (7) of the stopper. The side broom changes the width (5).

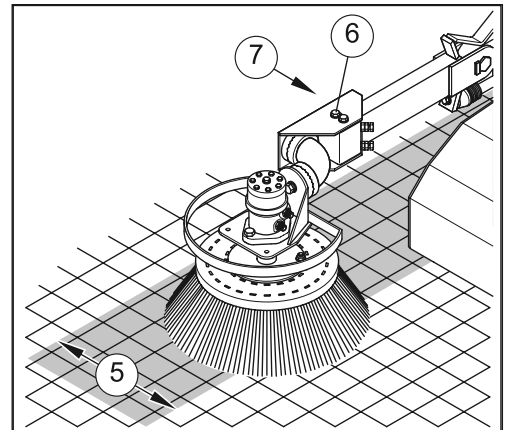

Setting the side broom - support point

- The side broom is intended to sweep out the side borders between a 12 o'clock and 3 o'clock position; see arc (8).
- Shift clamping discs (9). The angle (10) will be adjusted.
- Shift the clamping discs (11). The pressure angle (12) is adjusted.

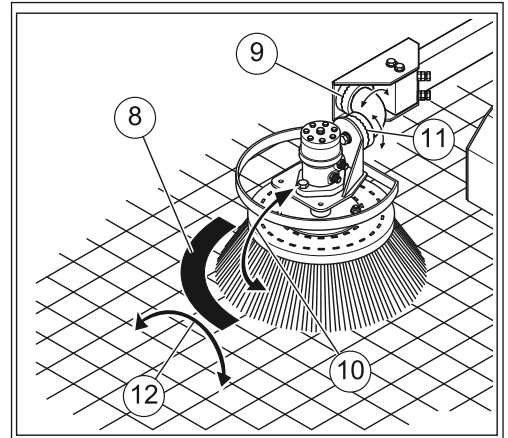

Attention Check all screw connections to ensure they are firmly seated.

- Perform functionality check.

3.4.4 Rpm adjustment



The safety instructions from Chapter 3.3 apply.

Brush shaft

For sweeping machines with direct hydraulic motor intake, the rpm adjustment is handled by means of the hydraulic fluid pressure coming from the carrier vehicle. This depends on the types of the carrier vehicle and its equipment.

The rpm adjustment of the main sweeping drum on a Profi Champ sweeping machine equipped with a 3-way current regulator is handled by means of the adjustment screw (1) of the 3-way current regulator (2).

(Clockwise = acceleration, counter-clockwise = restriction)

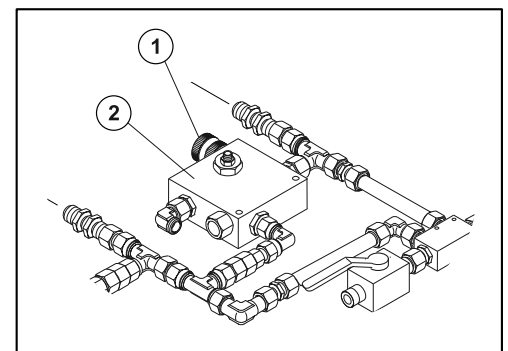

Side broom

The rpm adjustment of the side broom is handled by means of the adjustment screw (3) of the one-way restrictor (4).

(Clockwise = acceleration, counter-clockwise = restriction)

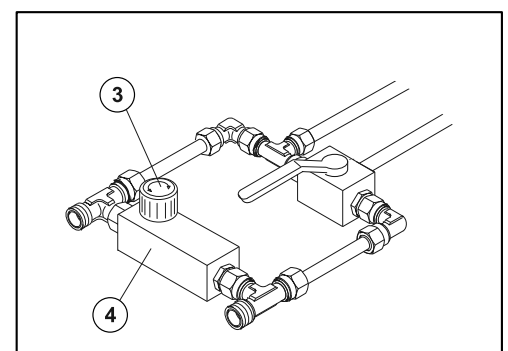

3.4.5 Emptying the dirt collection vessel



The safety instructions from Chapter 3.3 apply.

The dirt collection vessel is opened via one hydraulic cylinder. The tap for must be open for emptying.

- A high-level filling flap is float-mounted in the dirt collection vessel. This high-level filling flap serves to increase the volume of the swept material. During emptying of the dirt collection vessel, the high-level filling flap swings away from the dumping area.
- Lift the Profi Champ sweeping machine.

Attention

No person must be present below the machine during emptying.

- Flip the control lever for the sweeping machine hydraulics in the carrier vehicle. The direction of flow changes and the collector vessel opens.
- Close collector vessel by flipping back the previously mentioned control lever in the carrier vehicle.

Note

If the swept material is wet, it may be useful to actuate the control lever briefly several times to facilitate emptying.

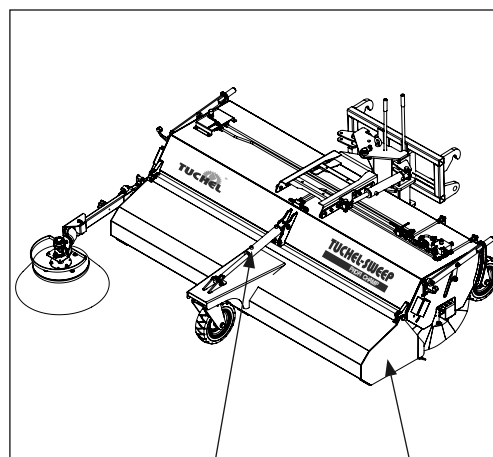

Hydraulic
cylinder collector
vessel drainage

Dirt
collection
vessel

3.4.6 Open sweeping



The safety instructions from Chapter 3.3 apply.

- Lift the Profi Champ sweeping machine and keep it close to the ground.
- Flip the respective control lever for the sweeping machine hydraulics in the carrier vehicle. This changes the direction of flow. Fully open the dirt collection vessel.
- Lower the Profi Champ sweeping machine until all castor wheels are contacting the ground and the sweeping machine is standing parallel to the surface to be cleaned.
- Close the intake hose to the hydraulic cylinder of the collector vessel. The tap points to the centre of the sweeping machine.
- Lock the opened collector vessel into place by twisting the control lever; it then remains open.

Note

Position of sweeping machine during operation in front of the carrier vehicle, see Chapter 3.4.2 Start-up!

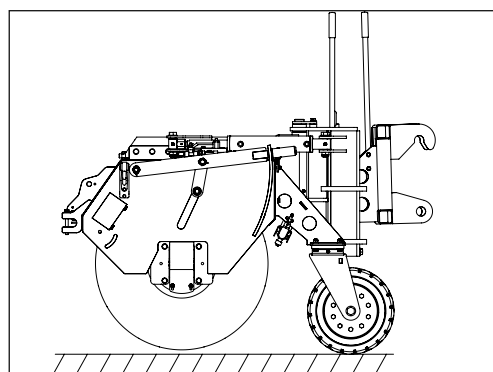
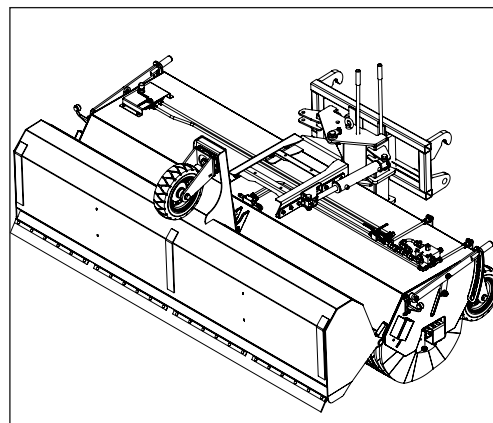

3.4.7 Side adjustment for open sweeping usage



The safety instructions from Chapter 3.3 apply. When used as an open Profi Champ sweeping machine, a side adjustment in relation to the side of the road must be carried out. (sweeping angle / swept material to the left or right).

Mechanical side adjustment

The sideways setting is handled by means of the adjustment bar (1) on the pivot point of the sweeping machine.

- Raise the machine slightly.
- Switch off the engine and take out the ignition key.
- Secure the carrier vehicle against unintended start-up.
- Raise the adjustment bar (1) and then turn the sweeping machine to the left or right; the desired sweeping angle is attained by turning the machine around the pivot point.
- Once the sweeping angle has been set, the adjustment bar (1) clicks into place in the intended drill hole.

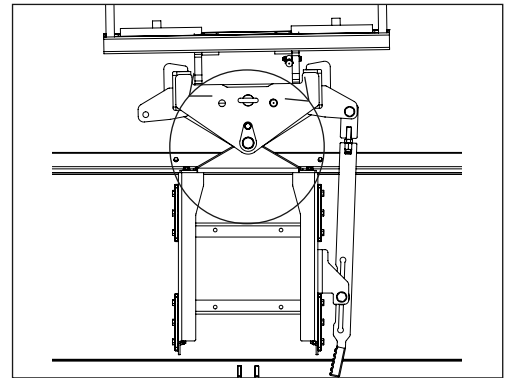
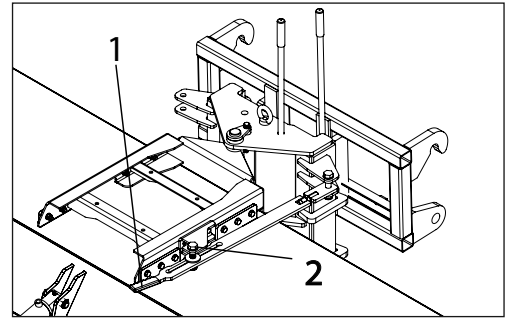

Overload protection



The safety instructions from Chapter 3.3 apply.

Note

To protect against overload upon encountering an obstruction when starting to drive, the adjustment bar (1) is secured by means of the locking bolt (3).

Attention

If the locking bolt has to be replaced, only use original spare parts offered by Tüchel Maschinenbau GmbH.

Hydraulic side adjustment

The sideways setting is handled by means of both of the hydraulic cylinders between the swivel console and the sweeping machine frame.

- Raise the machine slightly.
- Actuate the control lever for the second double-acting control circuit. The sweeping machine tilts to the right or left.

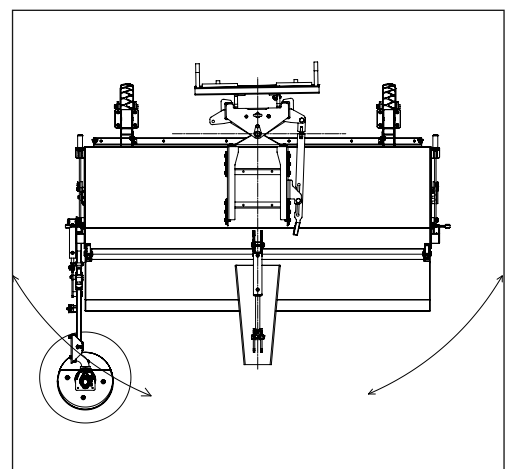

3.4.8 Readjustment of the sweeping profile



The safety instructions from Chapter 3.3 apply.

Note

When operating the Profi Champ sweeping machine, there should be a sweeping profile of $a = 6 - 10$ cm width (upon raising the sweeping machine, the width of the cleaned surface should be 6 - 10 cm).

Note

Check the sweeping profile on even ground!

If the width is not sufficient, or the ground contact pressure is too low, the suspension of the sweeping drum must be readjusted evenly on both sides via the raster lever system.

Attention

Take the sweeping drum's net weight into account!

Attention

Ensure that the routing of the hydraulic lines is free of twisting and kinks.

- Lift the sweeping machine and keep it close to the ground.
- Pull the raster lever (1) of the raster setting backwards
- Latch the raster level into the desired position on the adjustment raster (2).
- Carry out the raster setting of the sweeping drum evenly on both sides.
- Check that the width of the sweeping profile is $a = 6 - 10$ cm.

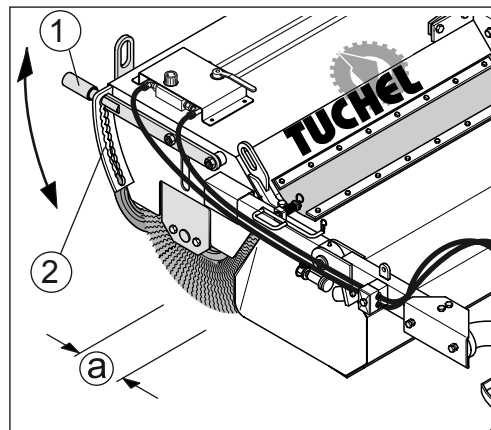

3.5 Deinstallation



The safety instructions from Chapter 3.3 apply.



Only perform work on the sweeping machine with the engine switched off and the hydraulics depressurised. Pull the ignition key and secure the carrier vehicle against unintended start-up and movement.



Park the Profi Champ sweeping machine on a firm and level surface in a dry and clean place and secure it against rolling away.



Accident hazard!
Ensure a secure standing of the Prof Champ sweeping machine.

Attention

If the Profi Champ sweeping machine is not to be reused immediately after deinstallation, the Storage section should also be read and observed!

- Lower the sweeping machine until the castor wheels touch the ground. The castor wheels point toward the carrier vehicle.
- Deinstall the sweeping machine with the dirt collection vessel closed and empty.
- Close the tap for the hydraulic cylinder (for drainage).
- Close side broom tap. Tilt the side broom upwards and secure it (see Chapter 3.4 Transport trips).
- For the open sweeping Profi Champ sweeping machine, shift the two supports (5) downwards and secure them.
- Disconnect hydraulic lines and electrical lines on the vehicle.



Accident hazard! Do not place hydraulic hoses and electrical connection lines on the ground as they pose a tripping hazard. Place the hoses and lines on top of the Profi Champ sweeping machine.

Note

Seal hydraulic connector barrels with dust caps. Soiling leads to damage on the hydraulic system.

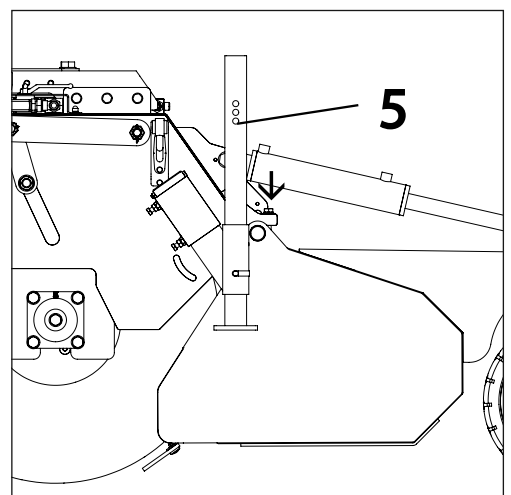
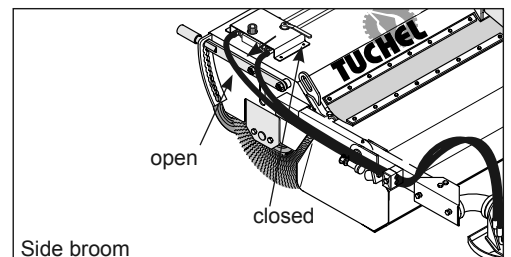

3.5.1 Quick change receptacle



The safety instructions from Chapter 3.3 apply.

- Initiate hydraulic locking (2) of the receptacle through actuation of the corresponding control lever in the carrier vehicle.
- Initiate mechanical locking (2) of the receptacle by removing of the corresponding locking bolt.
- Lower lifting gear until the receptacle bolt is located beneath the receptacle openings (1).
- Ensure that the path is clear for driving backward.
- Drive vehicle backwards.

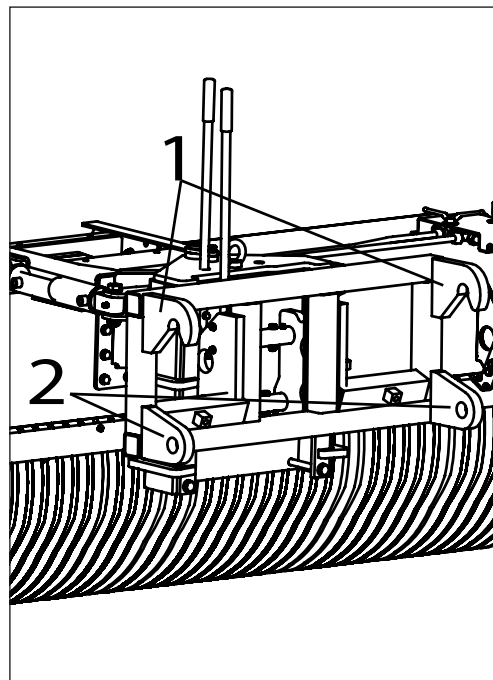

3.5.2 Three-point mount



The safety instructions from Chapter 3.3 apply.

- Unlock the upper hook and draft link hook according to the vehicle manufacturer's specifications. Refer to the operating manual of the carrier vehicle.
- Lower the upper hook and draft link hook until they completely unhook and release the receptacle bolts.
- Ensure that the path is clear for driving backward.
- Drive the carrier vehicle backward away from the sweeping machine.

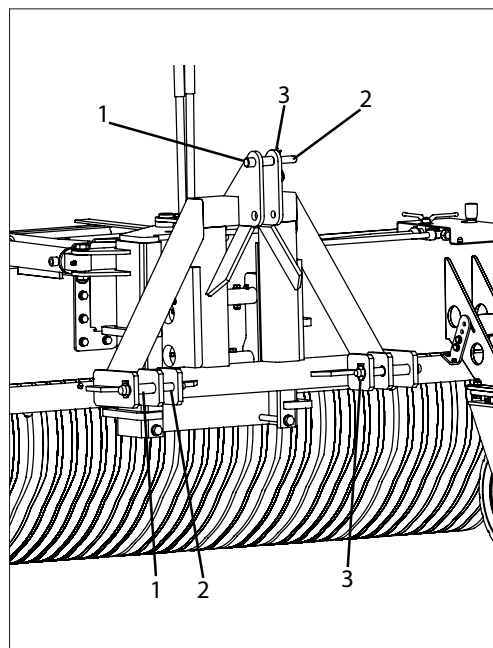

3.5.3 Fork arm receptacle



The safety instructions from Chapter 3.3 apply.

- Shift safety bracket downward (in the reverse order of attachment as described in chapter 3.3.3 Attachment).

Attention The lever clicks into place in the drill hole. (Perform steps 4-7)

- Disconnect the safety chain from the carrier vehicle and place across the machine's cover.
- Move the fork arms out of the receptacle openings of the fork arm receptacle.
- Drive vehicle backwards.

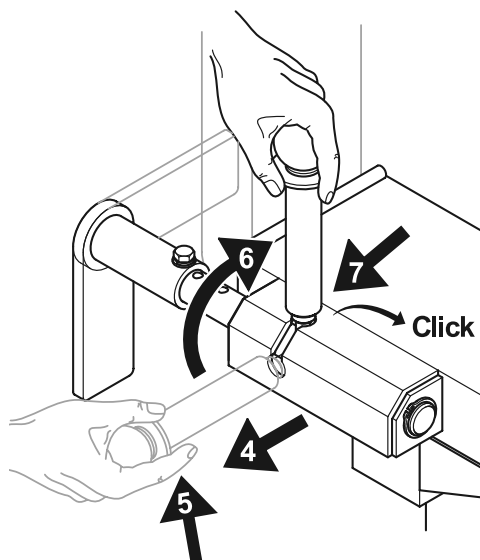

4 Service and maintenance

4.1 General



Carry out maintenance, repair work and modifications on the Profi Champ sweeping machine only if the hydraulic drive is switched off and hydraulic connections are disconnected. Secure the carrier vehicle against unintended start-up and movement!

Check the screws and nuts for tight fit for the first time after 5 operating hours, then regularly (approx. every 50 operating hours); re-tighten if necessary.

A = thread size (property class visible on screw head)

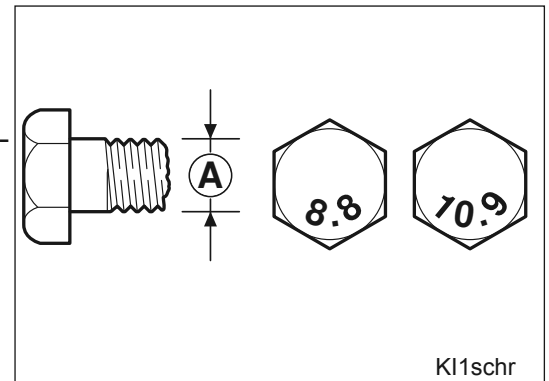

A ø	3.6	5.6	6.8	8.8	10.9	12.9
	M _A (Nm)					
M 6	3.43	4.51	8.73	10.3	14.71	17.65
M 7	5.59	7.45	14.22	17.16	24.52	28.44
M 8	8.24	10.79	21.57	25.50	35.30	42.17
M 10	16.67	21.57	42.17	50.01	70.61	85.32
M 12	28.44	38.25	73.55	87.28	122.58	147.10
M 14	45.11	60.8	116.7	135.27	194.17	235.36
M 16	69.63	93.16	178.46	210.84	299.1	357.94
M 18	95.13	127.40	245.17	289.3	411.88	490.34
M 20	135.33	180.44	348.14	411.88	576.50	669.26
M 22	162.4	245.17	470.72	558.98	784.45	941.44
M 24	230.46	308.91	598.21	710.99	1000.28	1196.42

All torques M_A are guide values for standard metric threads acc. to DIN 13. Friction coefficient 0.14 (new screw unlubricated). These values have been recommended as approximate values by various screw manufacturers. We can not accept liability for their application.

Replace self-locking nuts after each unscrewing.

- Regularly check the hydraulic lines.
- Hydraulic lines must be replaced no later than after 6 years of usage (including storage time of at most 2 years).
- Replace hydraulic lines that are damaged or aged.
- The replacement hoses must meet the technical requirements of the manufacturer.

4.2 Replace brush rings



Carry out maintenance, repair work and modifications on the Profi Champ sweeping machine only if the hydraulic drive is switched off and hydraulic connections are disconnected. Secure the carrier vehicle against unintended start-up, movement and sinking!



Do not go beneath or work under a raised machine.

Attention

Always secure the opened collector vessel by twisting the tap. Additional mechanical safeguarding against closing of the vessel is necessary.

Attention

Replace brush rings only when the sweeping machine is attached to the carrier vehicle.

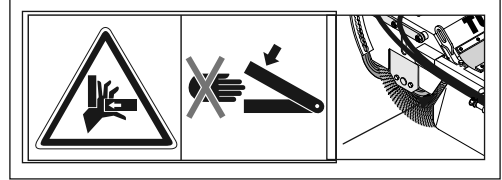

4.2.1 Brush shaft, internal motor



The safety instructions from Chapter 4.2 apply.

- Lift the sweeping machine (approx. 200 mm) and open the collector vessel.



Secure the sweeping machine and carrier vehicle against unintended restart, sagging and movement!

- Close the tap (1) for the drainage cylinder (must point toward the rear castor wheels).
- Put the raster lever system (2) in the lowest position on both sides.
- Lower the sweeping machine until the complete brush shaft is lying on the floor.

Note

Turn off the pressure on the hydraulic lines of the sweeping machine in the carrier vehicle.

Attention

Secure the sweeping machine and carrier vehicle against unintended restart, sagging and movement!

- Loosen and remove the attachment screws (3) of the motor bearer (4) and bearing (5).

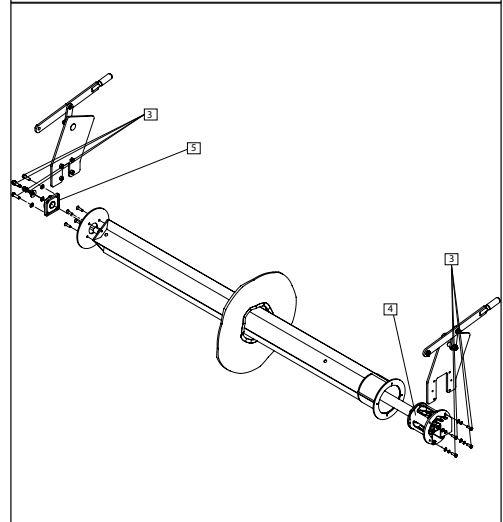
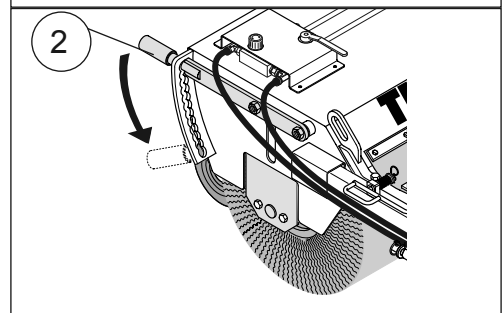
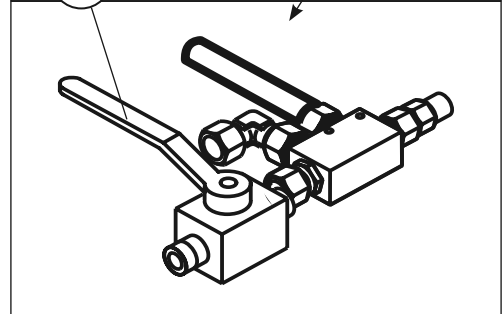
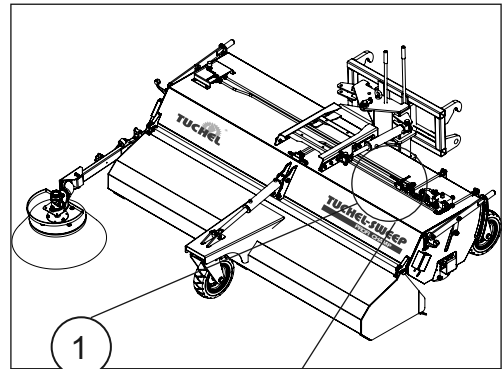

- Set the raster lever system (2) in the highest position on both sides.
- Raise the sweeping machine frame until the brush shaft is completely unobstructed. (look out for the hydraulic hoses).



Entanglement and pinching of the hydraulic hoses will cause damage.

Note

A mechanical safeguard against lowering of the collector vessel is necessary. (pinch point between the side sections of the sweeping machine frame and collector vessel.)

Attention

Secure the sweeping machine and carrier vehicle against unintended restart, sagging and movement!

- Pull the motor bearer (4) with hydraulic motor (7) out of the drum shaft (8).
- Pull the drum shaft (8) out beneath the sweeping machine.
- Lower the sweeping machine frame (6) and place it on the rear support rollers.
- Remove the four countersink screws (9) and unmount the holding plate (10).
- Replace worn-out brush rings. (For the quantity of brush rings, see the list of spare parts. Brush set, Snowline, Sunline, Beeline, 50% Sunline and 50% corrugated wire are possible):
- Before assembly, clean all parts and replace if necessary.

Note

Refer to the list of spare parts for the article number of the component; for the address, see the reverse side this manual or via e-mail at service@tuchel.com

- The assembly of the brush shaft is carried out in the opposite order of the deinstallation.

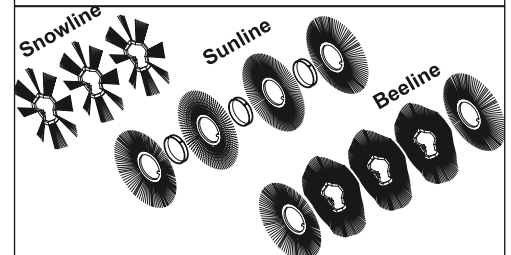
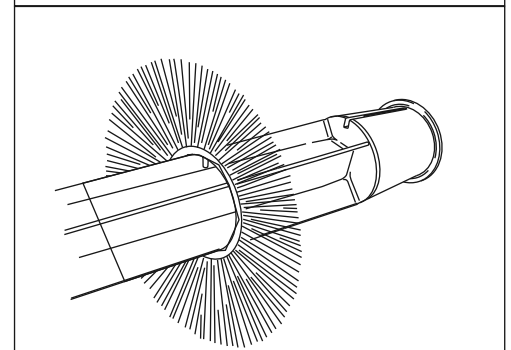
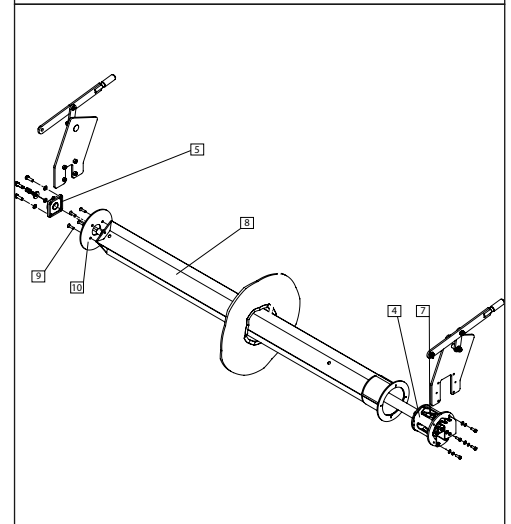
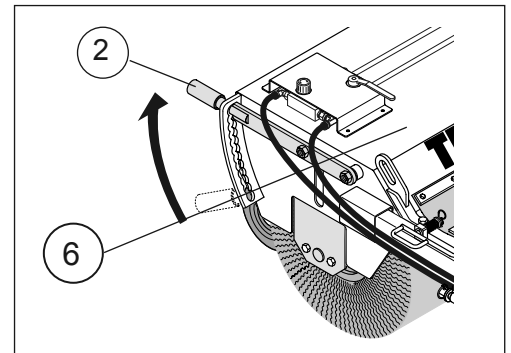

4.3 Replacing the plate broom



Carry out modifications on the Profi Champ sweeping machine only if the hydraulic drive is switched off and hydraulic connections are disconnected. Secure the carrier vehicle against unintended start-up and movement!

- Tilt the side broom upward (move from pos. A to pos. B) and click the lever (4) into place (5) (see Chapter 3.2.3).
- Screw off the three hexagonal nuts (1).



Take the plate broom's net weight into account.

- Remove old plate brooms (2) and drill a hole through the new plate broom to suit the flange (3).
- Mount plate broom using new self-securing nuts.
- Swing the side broom into operating position and readjust as described in Chapter 3.4.3.
- In case of hydraulically retractable side brooms, the broom must be retracted. Replacement of the broom plate corresponds to the procedure for the mechanically retractable side broom.

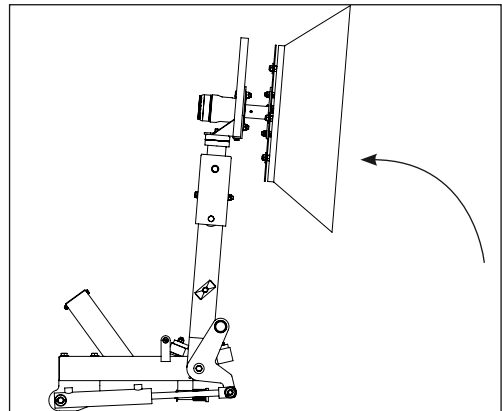
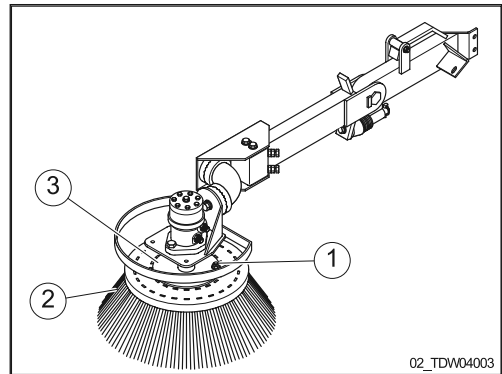
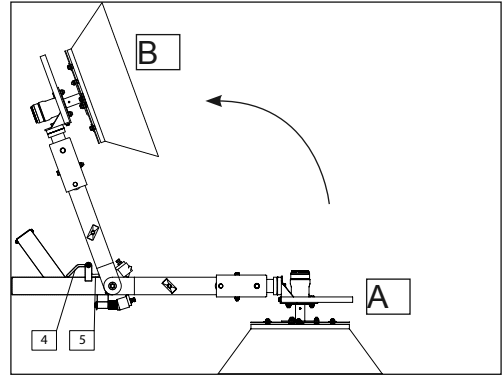

4.4 Replacing the Vulkollan rail



Carry out modifications on the sweeping machine only if the hydraulic drive is switched off. Secure the carrier vehicle against unintended start-up, movement and sinking!

Attention

Replace Vulkollan rail only when the sweeping machine is attached and lifted.

Attention

The dirt collection vessel must be empty and completely open.



Do not go beneath or work under a raised machine.



Secure the sweeping machine and carrier vehicle against unintended restart, sagging and movement!



Always secure the opened collector vessel by twisting the tap. Additional mechanical safeguarding against closing of the vessel is necessary.



Take into account the net weight of the impact rail and the Vulkollan rail. • Loosen the fastening nuts (3) and screws (4) along the entire length of the Vulkollan rail (1).

- Remove the impact rail (2) and the old Vulkollan rail (1).
- Replace the Vulkollan rail (1).

Note

The installation is carried out in the opposite order.

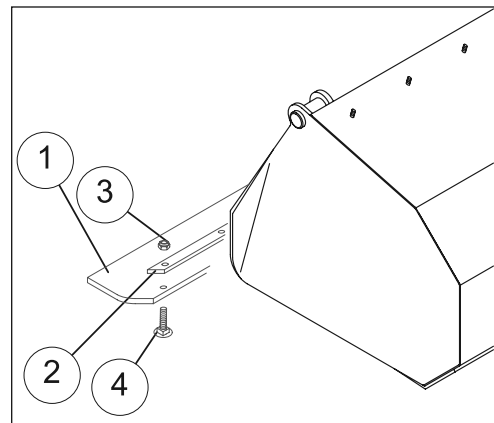

4.5 Water spraying device

The water filter is located at the suction hose (4) in the water tank (1).

Note

The state of the filter sieve must be checked every 50 operating hours and cleaned if necessary.

- Unscrew water tank lid (2).
- Pull the suction hose (4) out of the water tank opening (3). Unscrew the housing lid (7).
- Clean the filter sieve (6) with water.
- Screw the housing lid (7) with filter sieve (6) onto the housing (5).
- Place the suction hose (4) back in the water tank (1) and screw on the water tank lid (2).

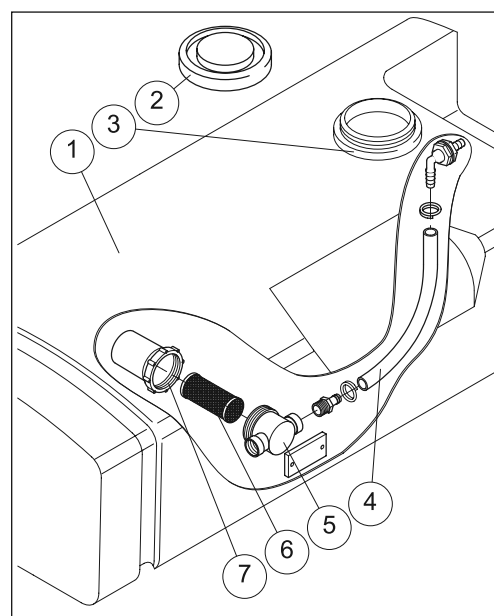

4.6 Lubrication plan

Note

Grease the bearings weekly. Use grease according to DIN 51502 (e.g., Gresalit 2 by Westfalen).

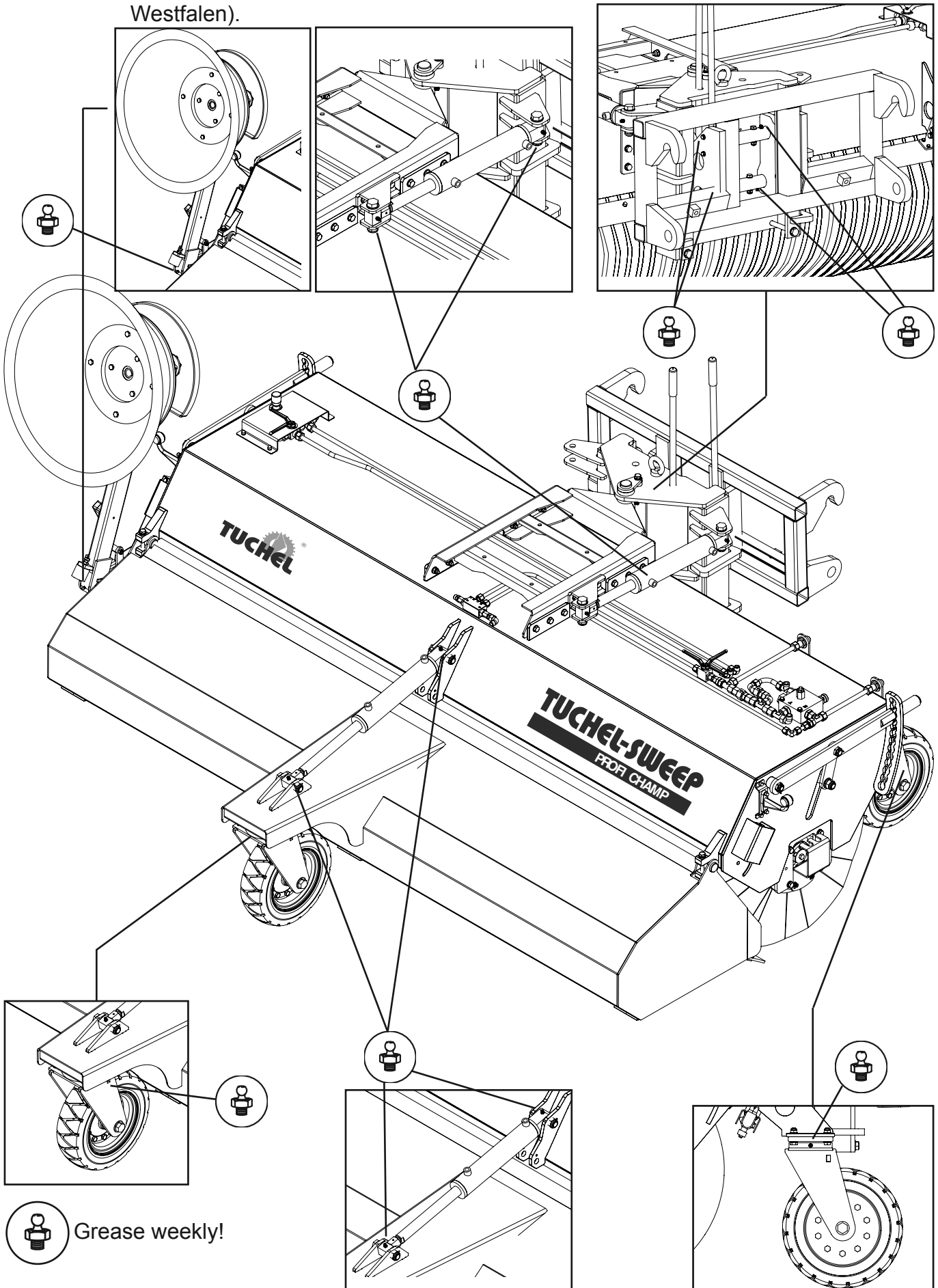

4.7 Malfunctions; causes and rectification

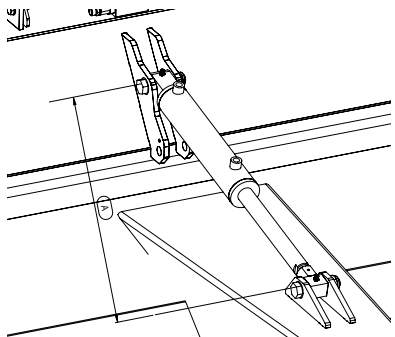
Malfunction	Cause	Rectification
<p>1. Sweeping drum does not turn</p> 	<ul style="list-style-type: none"> • Hydraulic connections not correct • Pressure or volume flow too low • Hydraulic motor defective • Flow control valve setting • Dimension A must be 777 mm (centre-centre) 	<ul style="list-style-type: none"> • Check connections • Ask a qualified workshop • Ask a qualified workshop • Check valve setting • Remove threaded joint on the collector vessel
<p>2. Dirt collection vessel does not tilt upwards</p>	<ul style="list-style-type: none"> • Intake hose closed • Hydraulic connections not correct • Hydraulic cylinder defective 	<ul style="list-style-type: none"> • Turn the 2-way-tap • Check connections • Ask a qualified workshop
<p>3. Water spraying device does not function</p>	<ul style="list-style-type: none"> • Water tank empty • Fuse in the cabinet defective • Water filter clogged • Nozzles clogged 	<ul style="list-style-type: none"> • Top up water • Replace the fuse • Clean water filter • Clean nozzles
<p>4. Side broom does not move</p>	<ul style="list-style-type: none"> • Intake hose closed • Hydraulic connections not correct • Flow control valve setting • Hydraulic motor defective 	<ul style="list-style-type: none"> • Turn the 2-way-tap • Check connections • Check flow control valve setting • Ask a qualified workshop
<p>5. Sweeping result unsatisfactory</p>	<ul style="list-style-type: none"> • Broom adjustment • Broom rpm too fast/slow 	<ul style="list-style-type: none"> • Adjust the broom via the raster lever system • Adjustment of the broom rpm

Notes:

Notes:

Notes:



TUCHEL

MASCHINENBAU GmbH

Holsterfeld 15 • 48499 Salzbergen, Germany
Tel. +49(0)59719675-0 • Fax: 49(0)59719675-30
Internet: <http://www.tuchel.com>
E-mail: service@tuchel.com