

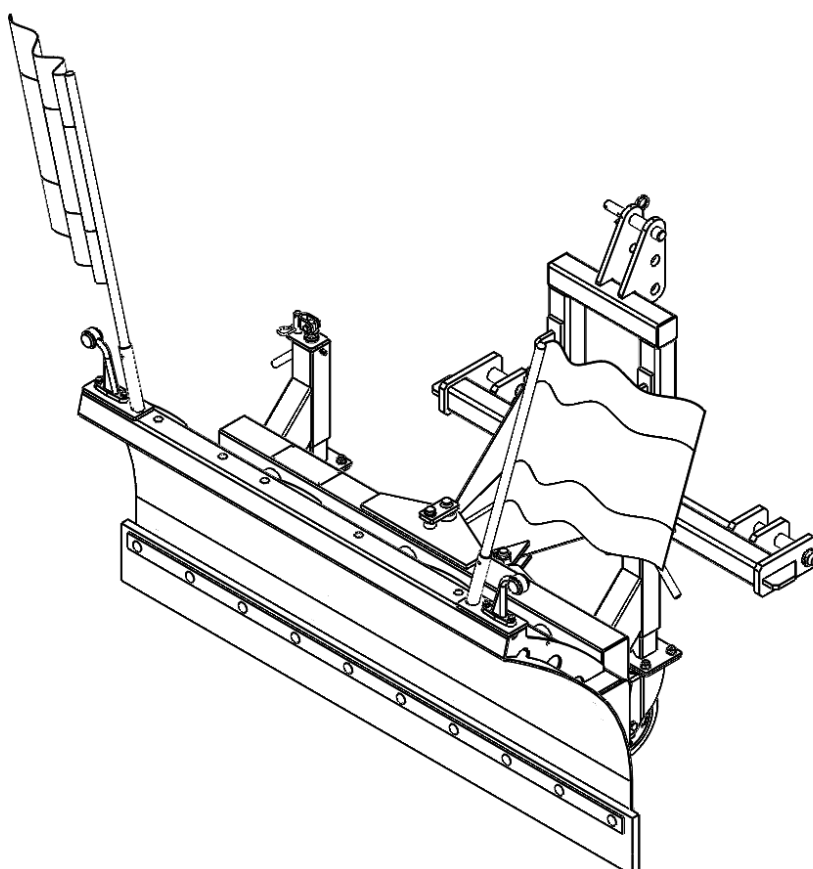

Operating Manual

SK-K snow blade

(Folding blade)



59000.0337.0000.00.001-01

04.14
Printed in Germany



Please read and observe the
operating manual before initial
start-up!
Please keep for future use!

Preface

Dear Customer,

Thank you for choosing a quality product from the extensive product range from Tuchel Maschinenbau GmbH. We also thank you for putting your trust in us.

Please check whether any damage has occurred during transport or if any parts are missing when you receive the attachment! Check that the delivered attachment is complete, including the special ordered equipment, using the delivery note. Only claims that are made immediately will lead to compensation!

Please read and observe the operating manual, particularly the safety notes, before initial start-up. After reading the instructions thoroughly, you can take full advantage of your newly acquired attachment.

Make sure that all operators of the attachment read the operating manual before putting it into operation.

Special equipment is available for the attachment. Not all of the descriptions contained in this operating manual may apply to your attachment due to the individual configuration of your attachment. Special equipment is marked in this operating manual.

If you have any questions about the handling of the attachment or this operating manual, please contact us.

Regular maintenance and timely replacement of worn or damaged parts will increase the service life of your attachment.

User evaluation

Dear reader,

our operating manual is updated regularly. Your suggestions help us to make the operating manual more user friendly. Please send any suggestions by fax or e-mail to:

Tuchel Maschinenbau GmbH

Operation: Holsterfeld 15

Postal address: D-48499

Salzbergen

Ph.: + 49 (0) 5971-9675-0

Fax.: + 49 (0) 5971-9675-30

E-mail: info@tuchel.com

1	General.....	1-1
1.1	Purpose.....	1-1
1.2	Product specifications.....	1-1
1.2.1	Manufacturing address	1-1
1.2.2	Labelling.....	1-1
1.2.3	Declaration of conformity	1-2
1.2.4	Specifications for enquiries and order	1-3
1.2.5	Formalities of the operating manual	1-3
1.2.6	Maximum load specifications.....	1-4
1.2.7	Connections	1-4
1.2.8	Energy consumption	1-4
1.2.9	Intended usage	1-4
1.2.10	Technical data sheet.....	1-5
2	Safety notes.....	2-1
2.1	Working in a safety-oriented manner	2-1
2.2	Organisational measures.....	2-2
2.2.1	User obligations	2-2
2.2.2	Operator obligations.....	2-2
2.2.3	Qualification of persons and activities carried out	2-3
2.3	Product safety	2-4
2.3.1	Safe operation of the attachment.....	2-4
2.3.2	Safety and protective equipment	2-4
2.3.3	Structural changes	2-4
2.3.4	Spare and wearing parts and auxiliary materials.....	2-4
2.3.5	Warranty and liability.....	2-5
2.4	Basic safety notes	2-5
2.4.1	General safety and accident prevention information	2-5
2.4.2	Hydraulic system.....	2-7
2.4.3	Attachment.....	2-8
2.4.4	Cleaning, servicing and maintenance.....	2-9
2.5	Action-related safety notes and important information	2-10
2.5.1	Action-related safety notes	2-10
2.6	Warnings and instructions	2-11
2.6.1	Warning notes.....	2-11
3	Product description	3-1
3.1	Overview – components	3-1
3.1.1	Description of the product and accessories.....	3-2
3.2	Attachment parts	3-3
3.2.1	Blade clearing lip.....	3-3
3.2.2	Castor wheels	3-3
3.2.3	Angling system.....	3-4
3.2.4	StVZO kit.....	3-4

4	Coupling and uncoupling of the attachment.....	4-1
4.1	Initial attachment	4-1
4.2	Attaching the SK-K snow blade	4-2
4.2.1	Quick change receptacle	4-3
4.2.2	Fork arm receptacle.....	4-4
4.2.3	Frontal attachment with 3-point linkage.....	4-5
4.2.4	Front attachment - coupling triangle	4-7
4.3	Operation	4-9
4.4	Transport trips	4-9
4.4.1	Start-up	4-9
4.4.2	Work position for attachment with roller-floating tunnel	4-11
4.5	Side adjustment.....	4-12
4.5.1	Mechanical side adjustment	4-12
4.5.2	Hydraulic side adjustment	4-13
4.6	Checking the functionality of the attachment	4-14
4.7	Detaching the SK-K snow blade	4-14
4.8	Storage.....	4-16
5	Hydraulic system.....	5-1
5.1	Hydraulic lines	5-1
5.1.1	Coupling hydraulic lines.....	5-1
5.1.2	Uncoupling the hydraulic lines.....	5-2
6	Cleaning, servicing and maintenance.....	6-1
6.1	Cleaning	6-2
6.2	Replacing the scraper bars	6-2
6.3	Replace fuse	6-3
6.4	Lubrication - overview.....	6-4
6.4.1	Lubricating points – snow plough	6-4
6.4.2	level compensation.....	6-4
6.4.3	Attachment parts	6-5
6.5	Malfunctions; causes and rectification	6-6
6.6	Hydraulic system	6-7
6.6.1	Labelling of hydraulic lines	6-8
6.6.2	Maintenance intervals.....	6-8
6.6.3	Inspection criteria for hydraulic lines	6-8
6.6.4	Installation and removal of hydraulic lines.....	6-9
6.7	Screw tightening torques	6-10
7	Appendix	7-1
7.1	Hydraulic circuit diagrams.....	7-1
7.2	Notes.....	7-2

Index

A

Action-related safety notes	2-10
Attachment parts	3-3
Appendix	7-1

C

Coupling and uncoupling	4-1
Checking the functionality of the attachment	4-13
Cleaning, servicing and maintenance	6-1

D

Declaration of conformity	1-2
---------------------------------	-----

E

Enquiries and order	1-3
Energy consumption	1-4

H

Hydraulic system	6-7
------------------------	-----

I

Intended usage	1-4
----------------------	-----

L

Labelling	1-1
-----------------	-----

O

Organisational measures	2-2
-------------------------------	-----

P

Product specifications	1-1
Product description	3-1

S

Safety notes	2-1
Start-up	4-9
Storage	4-16

T

Technical data sheet	1-5
----------------------------	-----

W

Warranty and liability	2-5
Warnings and instructions	2-11

1 General

This operating manual applies to the SK-K snow blade attachment.

1.1 Purpose

SK-K 150 - 225 snow blade attachment is designed exclusively for use as a snow blade for winter service. The one-sided snow blade with spring-segment overload protection can be used in the right, left and straight positions.

The snow blade is attached by means of the mechanically or hydraulically actuated quick change receptacle of the respective carrier vehicle, insertion of a pallet fork in the fork arm pockets or coupling triangle, or attachment on the 3-point linkage.

Various optional equipment allows for adaptation to different working environments. This optional equipment includes e.g. reinforced castor wheels, contour lights and warning flags, and hydraulic side adjustment with or without double pressure control valve to ease the work

1.2 Product specifications

1.2.1 Manufacturing address

Tuchel Maschinenbau GmbH
 Holsterfeld 15
 D-48499 Salzbergen, Germany
 Phone: +49 (0)5971 9675-0
 Fax: +49 (0)5971 9675-30
 E-mail: info@tuchel.com
 Spare parts: service@tuchel.com

1.2.2 Labelling

This information is found on the type label.

Model	<input type="text"/>
Serial no.	<input type="text"/>
Year of construction / order no.	<input type="text"/>
Maximum operating pressure [bar]	<input type="text"/>
Maximum oil flow [l/min]	<input type="text"/>
Net weight [kg]	<input type="text"/>

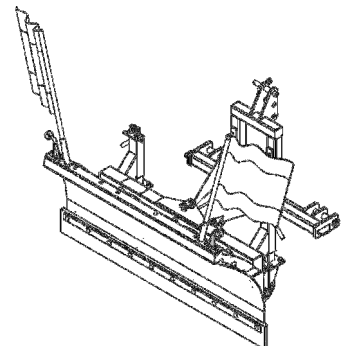

NOTE

The entire labelling (type label, safety label, etc.) constitutes a certificate and must not be altered or made illegible. It must be replaced if it is damaged or missing



1.2.3 Declaration of conformity

EU declaration of conformity

in the sense of the EU machinery directive 2006/42/EC

The manufacturer:

Tuchel Maschinenbau GmbH
Holsterfeld 15
D-48499 Salzbergen, Germany

hereby declares that the machine described below:

Brand: **SK-K snow blade (folding blade)**

Type: **1342-K**

Machine number:

complies with the regulations of the following EC directives:

- Machinery directive 2006/42/EC
- EMC directive 2004/108/EC (Electromagnetic compatibility)

Applied standards and technical specifications:

- DIN EN ISO 12100:2011
- DIN EN 13857:2008
- DIN EN 349:2008
- DIN EN 982:2009
- DIN EN 4254:2013
- DIN EN 703:2009

Salzbergen, April 2014

.....
Dieter Beckmann
Managing director

1.2.4 Specifications for enquiries and order

Address, see manufacturer address

Ph.: + 49 (0) 5971-9675-24

Fax.: + 49 (0) 5971-9675-4

Internet: <http://www.tuchel.com>

E-mail: info@tuchel.com



- The use of accessories or spare parts of other manufacturers is not permitted.
- Original accessories and original spare parts are to be used for safety reasons.
- The use of other accessories/spare parts invalidates the liability for the consequences thereof.

1.2.5 Formalities of the operating manual

Document number: 59000.0337.0000.00.001-01

Date of creation: 04.14

© Copyright Tuchel Maschinenbau GmbH 2014

All rights reserved.

Reprint, including extracts, only permitted with the approval of Tuchel Maschinenbau GmbH

1.2.6 Maximum load specifications



Only for snow blade with hydraulic side adjustment.

Maximum operating pressure at continuous load: 180 bar

1.2.7 Connections

Hydraulic side adjustment: (if present) 1 x double-acting control circuit

1.2.8 Energy consumption



Only for snow blade with hydraulic side adjustment.

Actuation type:	Hydraulic operation
Required oil quantity:	>10 l/min
Oil pressure required:	160 bar
Type of oil:	Hydraulic oil according to ISO VG 46 DIN 51524 (e.g. Vitam GF 46 by Aral)

1.2.9 Intended usage

The SK-K 150 - 225 snow blade attachment is designed exclusively for use as a snow plough for winter service on road surfaces.

The snow blade is not intended for uses other than that listed here. Any other use is improper use! In particular, we draw your attention to the fact that it is forbidden to clear or spread other materials.

The manufacturer does not accept any liability for damage arising from incorrect use; the risk rests solely with the user.

Proper usage also includes reading this operating manual as well as adherence to all notes contained herein, especially the safety notes. Also included is the adherence to the operating, maintenance, and repair conditions specified by us.

1.2.10 Technical data sheet

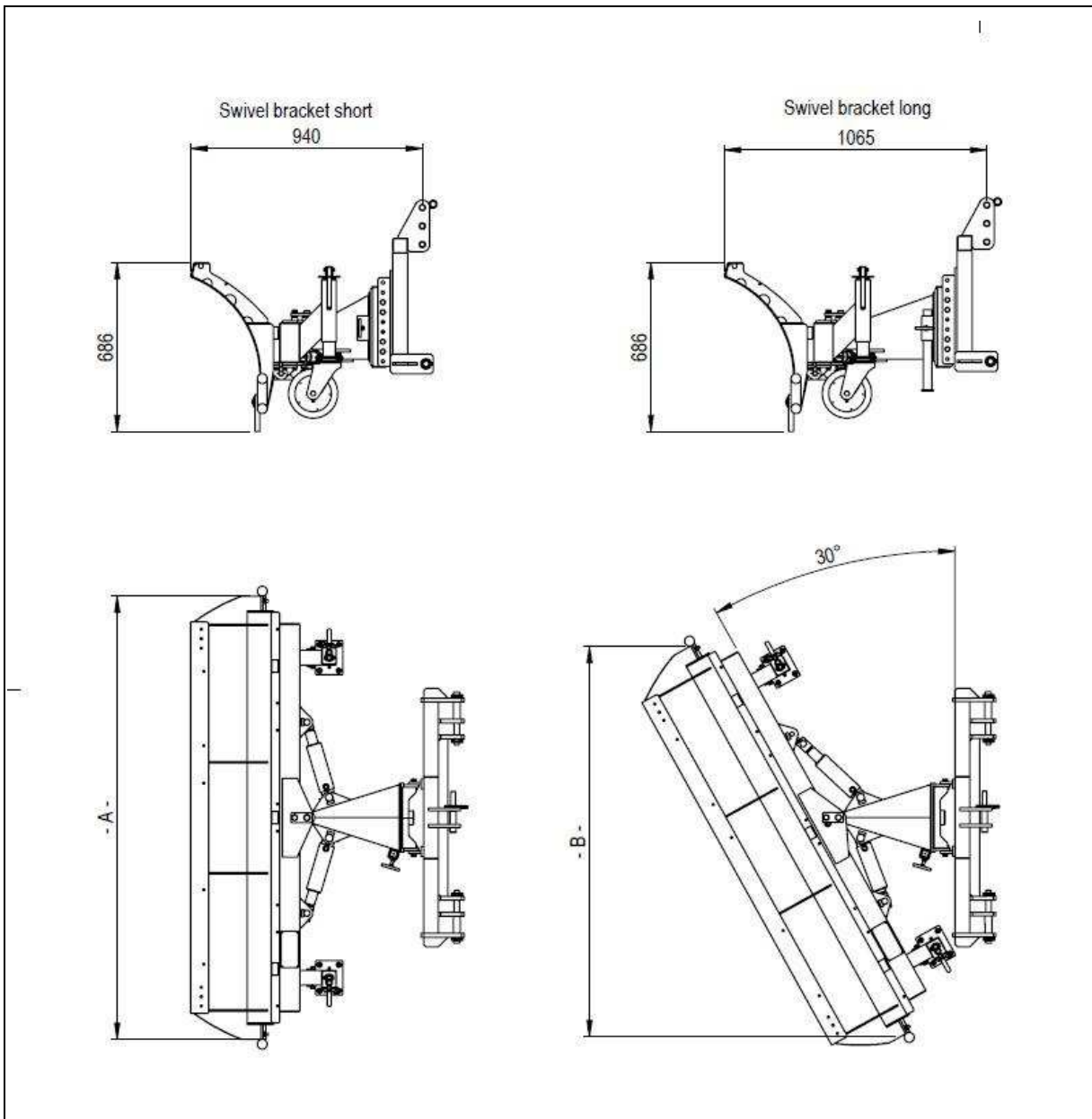

Technical data		SK-K 150	SK-K 180	SK-K 200	SK-K 225
Operating width	mm	1500	1800	2000	2250
Dimensions – A – Snow blade width	mm	1550	1850	2050	2300
Operating width if positioned at an angle of 30°	mm	1365	1628	1803	2021
Dimension - B - blade width at 30°	mm	1368	1640	1815	2034
Weights without receptacle / blade only	kg	76	91	101	113

2 Safety notes

This chapter contains important notes about safe and fault-free operation of the attachment for the user and the operator.



Observe all safety notes in this operating manual!

Most accidents are caused when the simplest safety rules are not observed.

You can help to prevent accidents by observing all safety notes in this operating manual.

2.1 Working in a safety-oriented manner

The attachment is built in accordance with the latest state of technology and the accepted technical safety rules. Nevertheless, there may be risks and adverse effects when using the attachment:

- risk to the life and limb of the operator or third persons,
- to the attachment itself,
- or other property.

Observe the following to ensure safe operation of the attachment:

- the safety notes, particularly:
 - the basic safety notes, action-related safety notes and action instructions,
 - the information about intended usage.
- the warnings on the attachment,
- the national, general regulations concerning occupational safety, accident prevention and environmental protection,
- the national traffic regulations during transport trips.

Do not operate the attachment unless it is in a technically safe and fault-free condition.

WARNING



Persons are at risk due to crushing, cutting, grabbing, pulling in or collisions if the machine and the attachment do not have sufficient traffic and operational safety!

Check traffic and operational safety before starting up the machine and the attachment.

2.2 Organisational measures



The operating manual:

- must always be kept at the usage location of the attachment!
- must be accessible to the operator and maintenance personnel at all times!

2.2.1 User obligations

The user is obliged:

- to observe the national, general regulations on occupational safety, accident prevention and environmental protection,
- to only allow persons to work with/on the attachment , who:
 - o are familiar with the basic rules of work safety and accident prevention,
 - o are trained to work with/on the attachment,
 - o have read and understood this operating manual.
- to keep all warning notes on the attachment in a readable condition,
- to replace damaged warning notes,
- provide the required personal safety equipment, such as:
 - o protective glasses,
 - o work gloves in accordance with DIN EN 388,
 - o safety shoes,
 - o protective suit,
 - o skin protection products, etc.

2.2.2 Operator obligations

All persons, who are assigned to work with/on the attachment, are obliged, before work begins:

- to observe the national, general regulations concerning occupational safety, accident prevention and environmental protection,
- to read the chapter "Basic safety notes", on page 2-1 of this operating manual and observe them,
- to read the chapter "Warnings and instruction notes", on page 2-11 of this operating manual and comply with the warnings when operating the attachment,
- to familiarise themselves with the attachment,
- to read the chapters of this operating manual, which are important for carrying out the tasks assigned to them.

If the operator determines that a piece of equipment is unsafe or not working properly, the operator must remedy this defect immediately. If this task is not the operator's responsibility or the operator lacks the relevant technical knowledge, the operator must report the defect to his/her superior or the user.

2.2.3 Qualification of persons and activities carried out



Only trained and instructed persons may work with/on the attachment. The user must clearly define the responsibilities of the personnel for operating, servicing and maintaining the attachment.

A person who is being trained may only work with/on the attachment under the supervision of an experienced person.

The user may only carry out the work described in this operating manual.

Only qualified workshops may carry out work on the attachment which requires specialist expertise. Qualified workshops have qualified personnel and suitable aids (tools, lifting and support equipment) for carrying out this work properly and safely.

This applies to all work:

- which is not mentioned in this operating manual,
- which is labelled in this operating manual with the phrase "workshop work".

Activity \ Persons	Person specially trained for the activity ¹⁾	Instructed person ²⁾	Persons with specialist training (qualified workshop) ³⁾
Loading / Transport	X	X	X
Start-up	--	X	X
Installation, setting up	--	X	X
Operation	--	X	X
Cleaning, servicing and maintenance	--	X	X
Troubleshooting and rectification	--	X	X
Disposal	X	--	--

Legend: X..permitted --..not permitted

- 1) A person who can take over a specific task and is allowed to carry it out for an appropriately qualified company.
- 2) An instructed person is someone who has received instruction and training if necessary concerning the tasks that are assigned to them and the potential dangers of improper behaviour, and has also be taught about the necessary safety equipment and protective measures.
- 3) Persons with specialist training are classified as a specialist (expert). They can assess the work assigned to them due to their technical training and knowledge of the relevant provisions and determine potential hazards.

Note: An equivalent qualification to professional training could also have been acquired by working in the area concerned for several years.

2.3 Product safety

2.3.1 Safe operation of the attachment

The attachment equipment may only be operated by a person in the driving seat of the machine if there are no persons in the hazard area of the machine. For more information, please refer to chapter "Hazard areas and danger points", page 2-16.

2.3.2 Safety and protective equipment

- Only operate the attachment if all safety and protective equipment has been properly attached and is fully functional.
- Faulty or removed safety and protective equipment can lead to dangerous situations.
- Check all safety and protective equipment for external damage and functionality before putting the attachment into operation.

2.3.3 Structural changes

- You may only make structural changes, attachments and modifications to the attachment if you have written approval from the manufacturer.
- The declaration of conformity and CE label of the attachment will lose its validity if any unapproved structural changes, attachments or modifications are made.
- Only use original parts or modification and accessory parts that have been approved by the manufacturer, so that:
 - the declaration of conformity and the CE label of the attachment retain their validity,
 - perfect functionality of the attachment is guaranteed.
- The manufacturer is not liable for damage caused by:
 - unauthorised changes made to the attachment,
 - use of non-approved modification and accessory parts,
 - welding and drilling work on supporting parts of the attachment.

2.3.4 Spare and wearing parts and auxiliary materials

Immediately replace parts which are not in perfect condition.

Only use genuine parts from the manufacturer or parts approved by the manufacturer. When using spare and wearing parts from third-party manufacturers, it is not guaranteed that they are designed and manufactured for the relevant stress and safety demands.

The manufacturer assumes no liability for damage caused by using unapproved spare and wearing parts or auxiliary materials.

2.3.5 Warranty and liability

Our general "Terms and conditions of sale and delivery" apply. These are handed to the owner upon conclusion of the contract at the latest.

Warranty and liability claims for injuries and property damage are ruled out if they are attributable to one or more of the following causes:

- improper use of the attachment,
- incorrect mounting, starting-up, operating and maintaining of the attachment,
- operating the attachment with defective safety devices or improperly mounted or inoperable safety and protection equipment,
- failure to follow the instructions in the operating manual regarding starting-up, usage and maintenance,
- unauthorised structural modifications to the attachment,
- inadequate monitoring of device components which are subject to wear and tear,
- incorrectly made repairs,
- catastrophic events caused by third party intervention or acts of God.

2.4 Basic safety notes

Basic safety notes:

- always applicable for safe operation of the attachment.
- summarised in the following subsections.

2.4.1 General safety and accident prevention information

- Also observe the generally valid national safety and accident prevention regulations as well as the safety notes in this chapter!
- Wear personal protection equipment when working on the attachment!
- Observe the warnings and instruction notes on the attachment. Important information for safe and fault-free operation of the attachment can be found there!
- As well as the basic safety notes in this chapter, please also observe the action-related safety notes in the other chapters!
- Remove people from the vicinity of the attachment before putting it into operation! Look out for children in particular!
- Do not carry people or transport objects on the machine! Carrying people and transporting objects on the attachment is prohibited!
- Adapt your driving so that you are always in control of the machine with the attachment attached at all times!

Take your personal skills, the road, the traffic, the visibility and the weather conditions, the driving characteristics of the machine and the influence of the attached attachment into consideration when doing this.

Coupling and uncoupling the accessory

- Always couple and transport the attachment using a suitable carrier vehicle!
- Couple the attachment to the specified equipment according to the instructions!
- Make sure that the following values are not exceeded by coupling the attachment to the frontal attachment of the machine:
 - the permitted gross weight of the machine,
 - the permitted axle loads of the machine,
 - the permitted support loads at the machine's connecting points,
 - the permitted towing capacity of the connecting device,
 - the permitted tyre load of the machine.
- Safeguard the machine and attachment from rolling away before coupling or uncoupling the attachment!
- Persons must not be standing between the machine and attachment while the machine is moving towards the attachment!
Assistants who are present may only act as guides next to the vehicles and may only move between the vehicles when they are at a standstill.
- Move the required support devices into the respective support position (stability) when coupling and uncoupling the attachment!
- Risk of crushing and shearing when operating the support devices!
- Be particularly careful when coupling to and uncoupling from the machine! There are crushing and shearing points in the vicinity of the coupling points between the machine and the attachment!
- Persons must not be standing between the machine and attachment when the three-point hydraulics are operated!
- Monitor the coupled supply lines. Coupled supply lines:
 - must give way slightly when driving around corners without tension, kinking or friction,
 - must not chafe against external components!
- Always place the uncoupled attachment in such a way that it is stable!

Use of the attachment

- Before starting work, familiarise yourself with all of the equipment and operating elements of the attachment, including the functionality thereof. There is no time for this once work has started!
- Wear closely fitting clothes! Loose fitting clothing increases the risk of grabbing or entanglement in the drive shafts!
- Only start up the attachment if all safety equipment is attached and in the protection position!
- Pay attention to the maximum load of the attachment and the permitted axle and support loads of the machine! If necessary, only drive with the load compartment partially filled!
- Persons must not be present:
 - in the working / hazard area of the attachment,
 - in the discharge area of the attachment,
 - in the rotating and swivelling area of the moving parts of the attachment,

- o beneath the raised and unsecured moving parts of the attachment!
- There are crushing and shearing points at the externally-operated (e.g. hydraulically) moving parts of the attachment!
- The externally-operated parts of the attachment may only be operated if there are no persons in the hazard area of the attachment!
- Safeguard the machine from unintentional start-up or rolling away before leaving the machine!
- Support the raised covers before standing beneath them!

Transporting the attachment

- Before transport, check:
 - o that the power supply lines are connected properly,
 - o the hydraulic system for obvious defects,
- Always ensure that the machine has sufficient steering and braking capability!
- The attachment attached to the machine and the rear weights which are present influence the driving behaviour of the machine as well as the steering and braking capability.
- Use rear weights if necessary!
- Always fasten the rear weights to the provided fixing points properly!
- Observe the maximum load capacity of the attached attachment and the permitted axle and support loads of the machine!
- Check the brakes before setting off! The machine must possess the prescribed braking deceleration for the combination of the machine plus the attachment!
- Take the projection and oscillating weight of the attached attachment into consideration when cornering!
- Avoid sudden turns particularly during uphill and downhill driving and when driving parallel to a slope!
- Bring all moving parts of the attachment into the transport position before transport trips!
- Secure all moving parts of the attachment in the transport position before undertaking transport trips. Use the transport locks provided!
- Adapt your driving speed to the prevailing conditions!

2.4.2 Hydraulic system

The hydraulic system is under high pressure.

- Make sure the hydraulic lines are connected correctly!
- Ensure that the hydraulic system of the machine and the attachment is depressurised when connecting the hydraulic lines!
- Do not block any operating levers on the machine which are used for directly carrying out hydraulic or electrical movements of components, e.g. folding, swivelling and pushing operations!
- The respective movement must stop automatically if the relevant operating lever is released.
- This does not apply to equipment movements that:
 - o are continuous,
 - o are automatically controlled,
 - o require a floating or pressure position for functional reasons.

Safety notes

- Before working on the hydraulic system:
 - o lower the attachment,
 - o safeguard parts of the attachment which are raised from unintentional lowering,
 - o depressurise the hydraulic system,
 - o turn off the engine of the machine,
 - o apply the parking brake,
 - o remove the ignition key!
- Have the hydraulic lines checked by an expert at least once a year in order to ensure that they are in a safe working condition!
- Replace hydraulic lines if they are obviously defective, damaged or old! Always use original hydraulic lines!
- The six year usage duration of the hydraulic lines must not be exceeded, including a maximum possible storage time of two years!
Even though they are stored properly and only subjected to the permissible loads, hoses and hose connections are subject to natural ageing, therefore their storage time and usage duration is limited. The usage duration can differ from this in accordance with empirical values, particularly taking the hazard risk into consideration. The same guideline values apply for hoses and hydraulic lines made from thermoplastics.
- Never try to seal up leaking hydraulic lines using your hands or fingers!
Liquids (hydraulic oil) escaping under high pressure may penetrate the skin and cause severe injuries!
In the event of injuries caused by hydraulic oil, seek immediate medical attention! Danger of infection!
- Do not use your bare hands to detect leaks because of possible severe risk of infection! Use a suitable aid when looking for leaks (cleaning spray, special leak-finding spray)!

2.4.3 Attachment

- Only one person may operate the attachment! Remove bystanders from the hazard area of the attachment!
- The following is strictly prohibited:
 - o climbing onto the upper edge of the receptacle,
 - o climbing or reaching into the receptacle with the engine of the machine running!
- No person may be present in the work area of the attachment!
Danger due to objects being flung out of the discharge opening.
- Remove all persons from the work area of the attachment before operating it!
- Do not place any foreign objects into the receptacle!

2.4.4 Cleaning, servicing and maintenance

- Carry out the required work for cleaning, servicing and maintenance when it is due.
- Safeguard the machine and the attachment from unintentional start-up and rolling away before cleaning, servicing or maintaining the attachment!
- Any residual energy present in the mechanical or hydraulic electronics may cause unintentional movement of the attachment.

Be aware of the presence of residual energy in the attachment when carrying out service and maintenance work. Components potentially carrying residual energy are marked with warnings. Detailed notes can be found in the respective chapters of this operating manual.
- Safeguard all operating materials such as hydraulic oil from unintentional start-up.
- Carefully fasten and secure large assemblies to lifting gear before replacing them.
- Regularly check that screws and nuts are firmly seated! Tighten up any loosened screws and nuts!
- Secure the raised attachment and raised attachment components to prevent unintentional lowering before cleaning, servicing or maintaining the attachment!
- Use suitable tools and gloves when replacing work tools with sharp edges!
- Check all loosened screw connections to ensure they are firmly seated. Check the operation of safety equipment and protective equipment after completing maintenance work.
- Oil, grease and filters must be disposed of properly!
- The substances and materials that are used for cleaning the machine, must be handled and disposed of properly, particularly:
 - o when working on lubrication systems and equipment,
 - o when cleaning with solvents.
- Disconnect the cable from the alternator and the battery of the machine before carrying out electrical welding work on the machine and the attached attachment!
- Spare parts must at least meet the specified technical requirements of the manufacturer! This is always the case when using original parts!
- Pay attention to the maintenance intervals of wearing parts!

2.5 Action-related safety notes and important information

Action-related safety notes and important information can be found in the operating manual. Signal words and symbols are used so that action-related safety notes and important information are recognised at a glance.

2.5.1 Action-related safety notes

Action-related safety notes:

- warn of danger which may occur in certain situations or in connection with certain behaviour,
- can be found immediately before a dangerous activity in the individual chapters,
- are labelled by the triangular safety symbol and a signal word. The signal word describes the seriousness of the potential threat.

DANGER



DANGER

marks an immediate danger with high risk, which will result in severe injuries (loss of body parts or long-term damage) or death if it is not avoided.

Failure to take heed of safety notes marked with "DANGER" will result in the threat of immediate severe injuries with potentially fatal consequences.

WARNING



WARNING

marks a potential danger with moderate risk, which may result in severe injuries or death if it is not avoided.

Failure to take heed of safety notes marked with "WARNING" may result in severe injuries with potentially fatal consequences.

CAUTION



CAUTION

marks a potential danger with low risk, which may result in minor or moderate injuries or damage to property if it is not avoided.

Failure to take heed of safety notes marked with "CAUTION" may result in minor or moderate injuries or damage to property.

2.6 Warnings and instructions



The following notes are attached to the attachment:

- Warning notes mark dangerous locations on the attachment and warn of dangers which may occur in certain situations or in connection with certain behaviour.
- Instructions contain information about the appropriate handling of the attachment.

Always keep these notices clean and legible! Replace illegible notices. Request warning notes and instructions from the dealer using the order number.

2.6.1 Warning notes

A warning note consists of 2 pictograms:

(1) Pictogram for describing the hazard

The pictogram shows a graphical description of the hazard, surrounded by a triangular safety symbol.

(2) Pictogram for avoiding the hazard

The pictogram shows graphical instructions on how to avoid the hazard.

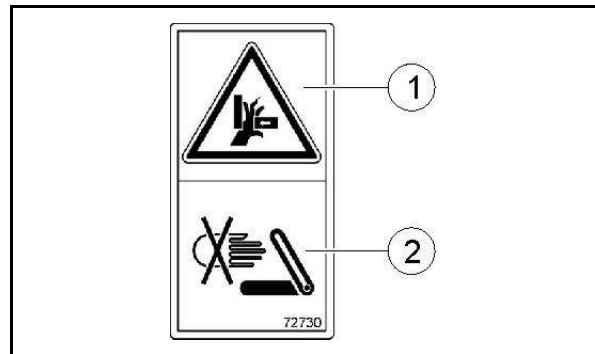

Explanation of the warning notes

The following list contains:

- all the warning notes present on the machine in the right-hand column,
- the following information in the left-hand column for the warning on the right:
 1. The order number.
 2. The description of the hazard, e.g. "Risk of crushing to fingers or hands, caused by accessible, moving parts of the attachment!"
 3. The consequences of failing to follow the instruction(s) for avoiding the hazard, e.g. "This hazard may cause severe injury and loss of body parts."
 4. Instruction(s) for avoiding the hazard, e.g. "Never reach into the hazard area while the engine of the machine is running with the hydraulic system connected. Remove persons from the hazard area of the attachment before the parts of the attachment start to move."

Order number and explanation

Warning note

40000340

Read and observe the operating manual and safety notes before putting the attachment into operation!



40000342

When lowering the machine, keep sufficient distance!

- Remove persons and animals from the hazard area
- Wait until all moving parts of the attachment are at a standstill before reaching into the hazard area.



40000343

Do not stand in the rotation area during operation!

- Remove persons and animals from the hazard area
- Wait until all moving parts of the attachment are at a standstill before reaching into the hazard area.

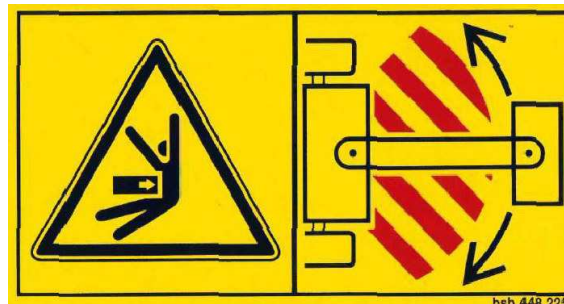

40000338

Risk of cutting or severing fingers and hands caused by accessible, moving tools!

This hazard may cause severe injuries and loss of body parts.

- Never reach into the hazard area while the motor of the machine is running with the hydraulic system connected.
- Wait until all moving parts of the attachment are at a standstill before reaching into the hazard area.



3 Product description



This chapter contains:

- comprehensive information about the design of the attachment.
- the designations of the individual assemblies.
- Read this chapter directly at the attachment, if possible. This is the best way to familiarise yourself with the attachment.

3.1 Overview – components

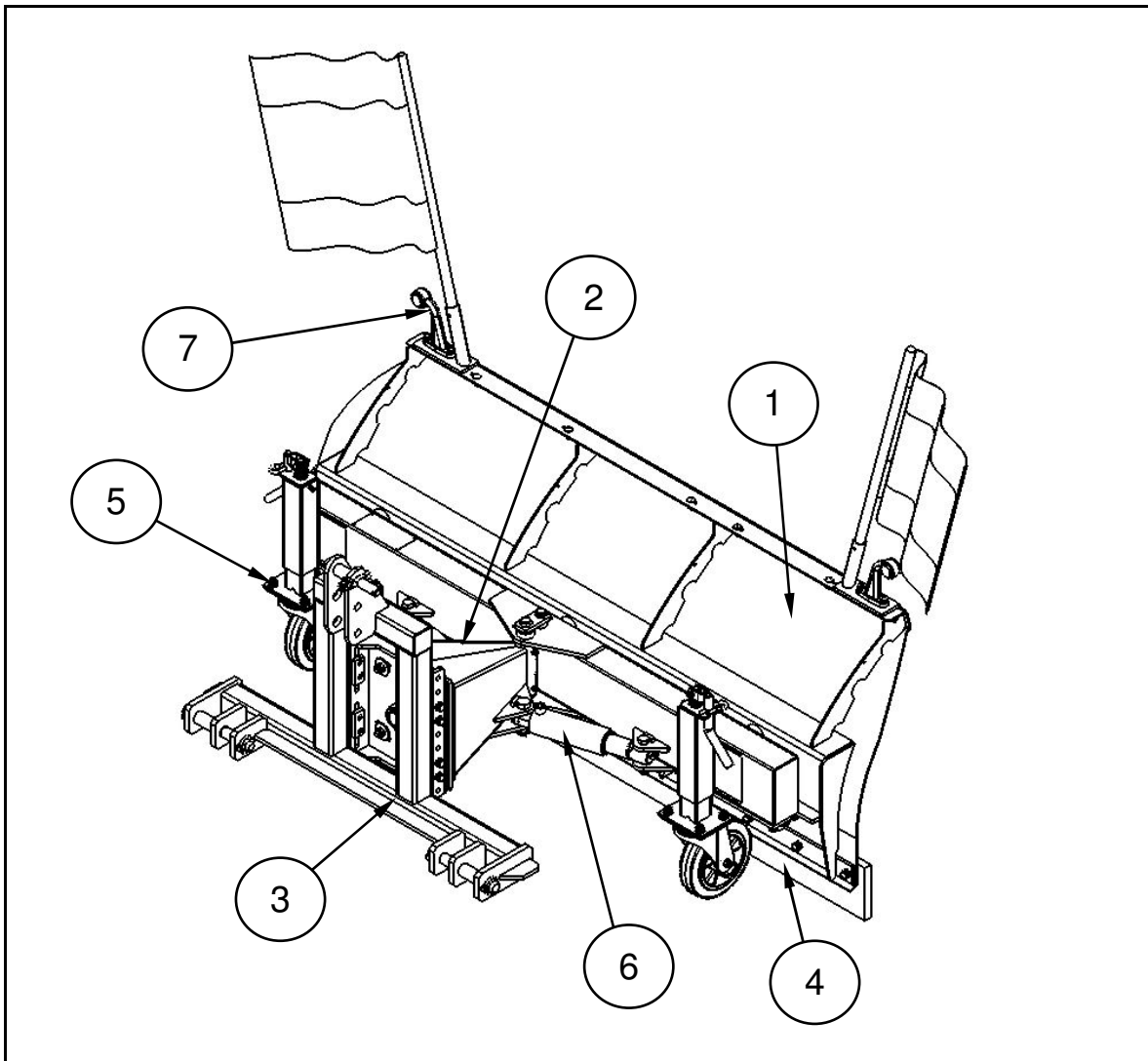

Fig. 3.1

- (1) Snow plough
- (2) Swivel element
- (3) Machine-dependent attachment console
- (4) Spring segments
- (5) Support wheels with height adjustment
- (6) Angling system
- (7) Contour illumination STVZO

3.1.1 Description of the product and accessories

- The SK-K folding snow blade attachment essentially consists of the carrier frame, the folding blade with Vulkollan lip, castor wheels with infinitely variable height adjustment, the mechanical or hydraulic angling system and the attachment console.
- The extremely stable welded construction and geometric shape of the snow blade enable problem-free clearing of snow.
- The blade, with continuous, wear-resistant Vulkollan lip, is flexibly connected to the carrier frame by means of bolts.
- Extra-stable torsion springs made of high-quality spring steel return the spring segments to their starting position.
- The castor wheels with height adjustment ensure scrape-free clearing and minimal wear of the Vulkollan lip.
- With the mechanical or hydraulic angling system, the snow blade can be swivelled up to 30° to the right or left.
- The snow blade is affixed to the attachment console by means of a swivel bolt.
- The attachment version of the attachment console is dependent on the carrier vehicle and the size of the snow blade.

3.2 Attachment parts



- Hydraulic side adjustment for angling the snow blade with the aid of two single-acting hydraulic cylinders.
- A double-acting control circuit is necessary for this purpose.
- Level compensation that compensates for surface irregularities across the driving direction.
- Reinforced castor wheels, (long-distance rollers) with rubber tires for high clearing speed.
- Steel lip.
- For clearing iced surfaces.
- Illumination attachment and warning flags with holders for travel in road traffic

3.2.1 Blade clearing lip

Blade clearing lip variants,

- Vulkollan
- Steel

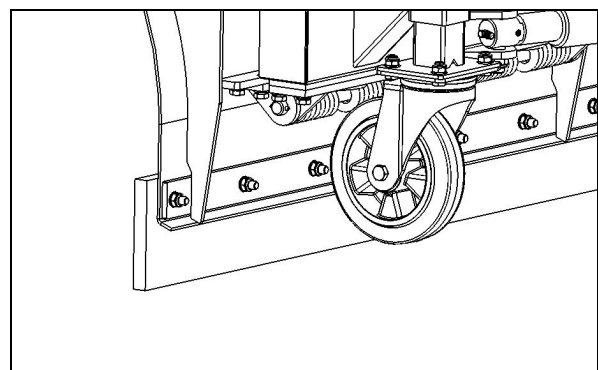

Fig.3.2

3.2.2 Castor wheels

The castor wheels have a diameter of 200mm and have infinitely variable height adjustment.

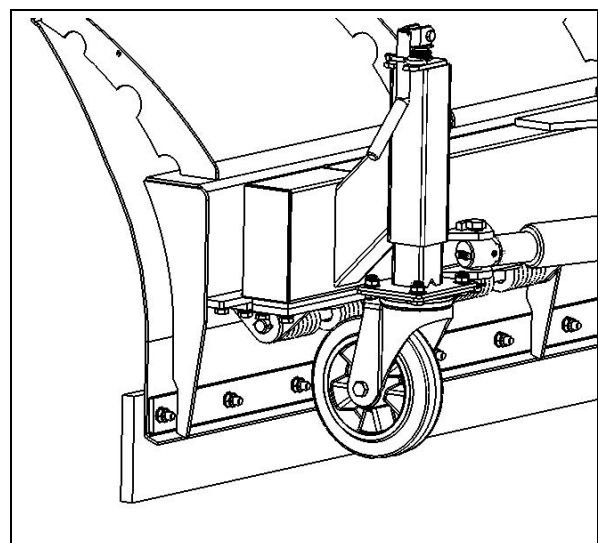

Fig.3.3

3.2.3 Angling system

Mechanical or hydraulic (optional) angling system and attachment console.

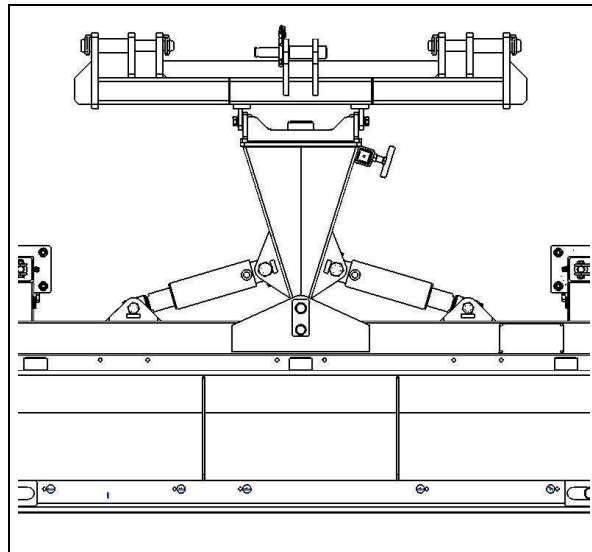

Fig.3.4

The snow plough can be inclined 30° to the left or right.

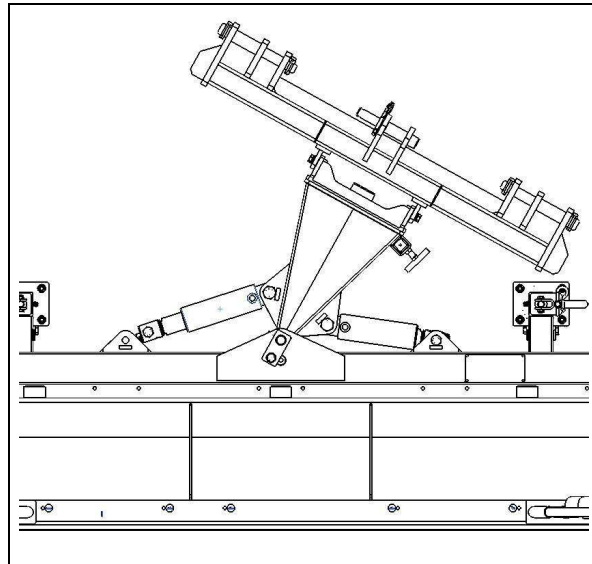

Fig.3.5

3.2.4 StVZO kit

StVZO equipment (warning flag, holder, contour lights)

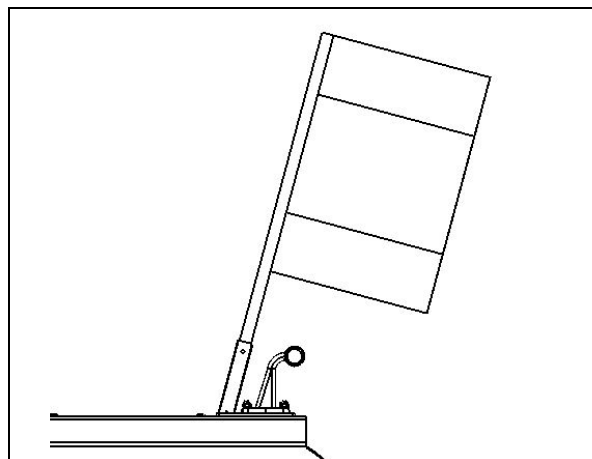

Fig.3.6

4 Coupling and uncoupling of the attachment



- Also observe chapter "basic safety notes" page 2-7, for coupling and uncoupling.
- Check the attachment for obvious defects when coupling and uncoupling. Pay attention to the "Operator obligations" chapter, page 2-3 when doing this.

WARNING



Risk of crushing and collisions for persons within the lifting range of the 3-point hydraulics of the machine when coupling and uncoupling the attachment!

Operate the control levers for the 3-point hydraulics of the machine:

- only from the intended workplace,
- never, if there are persons in the hazard area between the machine and the attachment,
- never, if you are in the hazard area between the machine and the attachment.

WARNING



Risk of crushing and collisions for persons can occur if the machine and the attachment inadvertently start up and roll off when coupling and uncoupling the attachment!

Safeguard the machine and the attachment from unintentional starting and rolling off before entering the hazard area between the machine and the attachment for coupling or uncoupling, see page 5-2.

4.1 Initial attachment

ATTENTION

During the initial attachment of the snow blade with illumination system, the cabinet is to be mounted at a suitable position in the carrier vehicle.

Connect cable (3) to the battery (-) and cable (4) to the parking light terminal.

Socket for illumination system (5), fuse (1), OFF - ON switch (2).

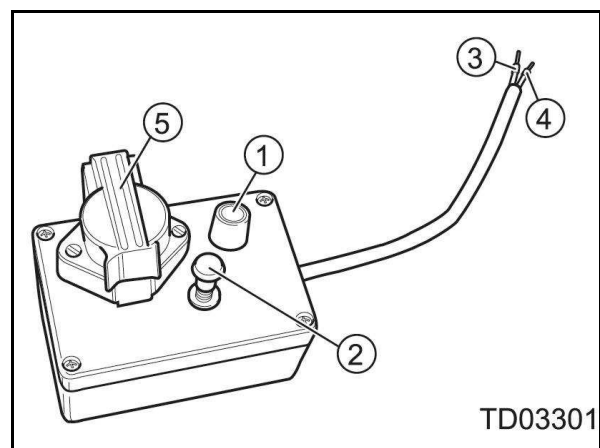

Fig. 4.1

TD03301

4.2 Attaching the SK-K snow blade

WARNING



Risk of crushing and collision for persons can occur if persons are present between the machine and attachment when coupling the attachment!

Remove persons from the hazard area between the machine and the attachment before moving towards the attachment.

Assistants who are present may only act as guides next to the machine and the attachment and may only move between the vehicles when they are at a standstill.

WARNING



Risk of loss of energy supply between machine and attachment due to damaged supply lines!

Pay attention to the routing of the supply lines when they are being connected. The supply lines:

- must give way slightly without any tension, kinking or friction,
- must not chafe against external parts.

WARNING



Risk of crushing, pulling in, catching and collisions for persons if the attachment inadvertently becomes detached from the machine!

- Observe the maximum permitted support, attachment and axle loads of the machine.
- Use and secure the devices provided for connecting the machine and the attachment appropriately.
- Before setting off with the attachment connected, check whether the quick change receptacle is correctly locked to the four-point attachment frame.

4.2.1 Quick change receptacle



- Observe attachment safety notes listed in chapter 4.2!
- Described and presented here as an example is a quick-change attachment version.
- Check the quick change receptacle and carrier vehicle receptacle for soiling and clean if necessary.

- Drive the carrier vehicle to within 300 mm of the snow blade.
- Lower the receptacle bolt of the carrier vehicle until below the receptacle openings (1).
- Approach with the carrier vehicle and raise the lifting gear.
- Insert the locking bolts of the carrier vehicle into the holes (2) and lock.

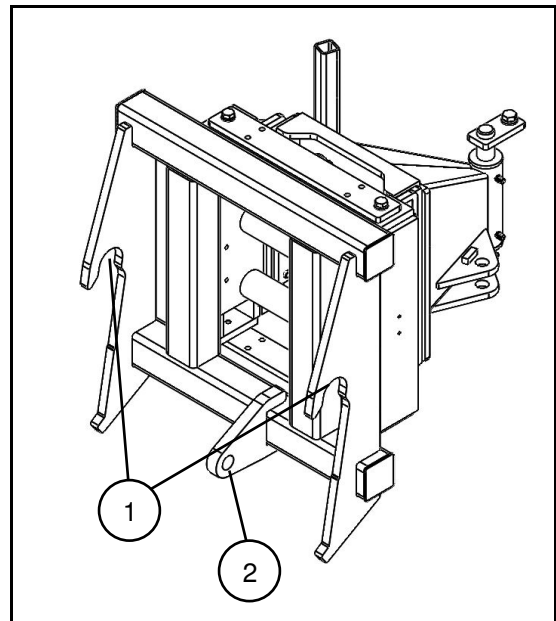

Fig.4.2

ATTENTION

Check the receptacle bolts and the locking bolts for proper seating.

- Lift out the attached SK-K snow blade.
- Loosen locking screws (3). Move the support (4) upward and resecure.
- If present, connect hydraulic hoses and electrical connection line to the carrier vehicle.
- Raise the SK-K snow blade and carry out a functionality check.

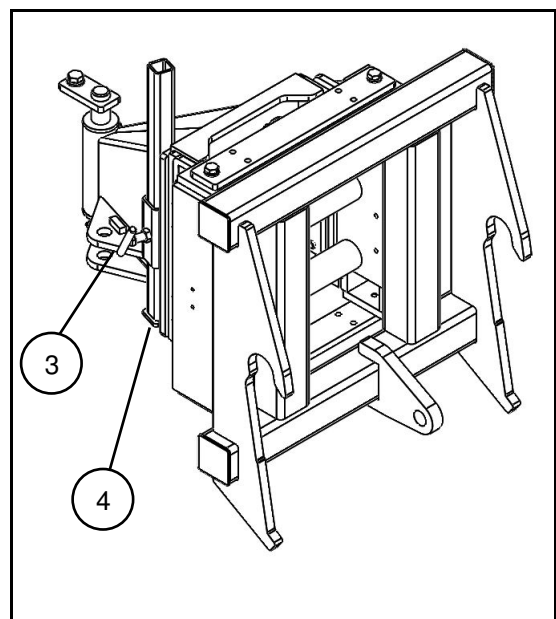

Fig.4.3

4.2.2 Fork arm receptacle



- Observe attachment safety notes listed in chapter 4.2!
- Check fork arm receptacle and arms for soiling and clean if necessary.
- The distance between the fork arms must be adjusted on the carrier vehicle before they are driven into the receptacles!

- Check the height between fork arms (1) and receptacle (2) before advancing and make adjustments on carrier vehicle.

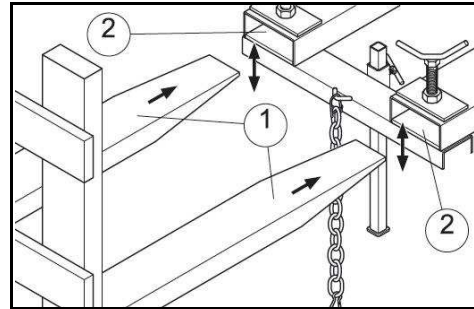

Fig.4.4

- A height adjustment can also be performed by moving the bars (3) with the screw connections (4),

ATTENTION

- Replace self-locking nuts each time they are unscrewed.

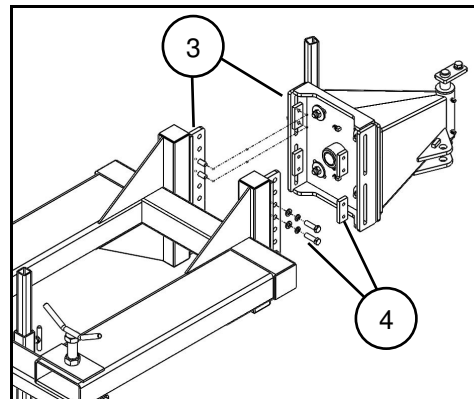

Fig.4.5

- Advance the carrier vehicle, inserting the fork arms (1) into the receptacles (2) and secure with clamping T-bolts (5) as well as with the chain (6).
- Wrap the chain (6) tightly through the slide carriage (7) and secure with the spring hook (8).

ATTENTION

Verify the correct seating of the attachment receptacle.

The chain (6) must not come into contact with the guides for the lifting gear of the forklift truck.

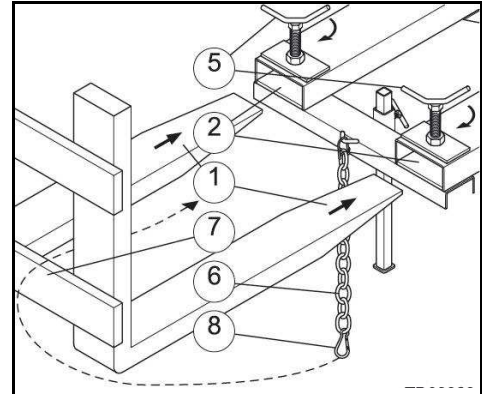

Fig.4.6

- Lift out the attached SK-K snow blade.
- Loosen the clamping T-bolt (10), move the support (11) upward and resecure.
- Hydraulic hoses and electrical connection lines, connect to the carrier vehicle if present.
- Raise the SK-K snow blade and carry out a functionality check.

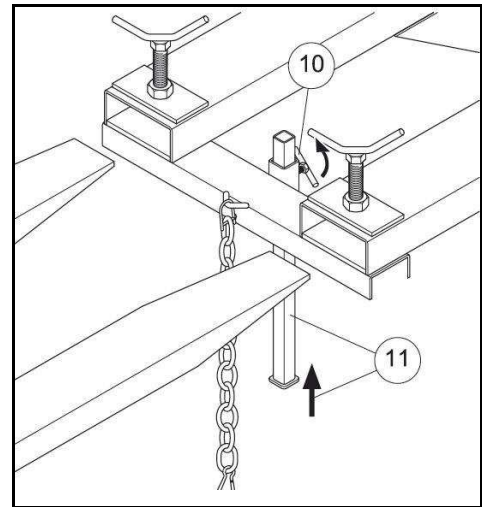

Fig.4.7

4.2.3 Frontal attachment with 3-point linkage



- Observe attachment safety notes listed in chapter 4.2!
- Check the 3-point linkage and 3-point linkage rods for soiling and clean if necessary.
- Before attaching, check the attachment height between 3-point linkage and 3-point linkage rods.

NOTE

Height adjustment by means of screw connection for the 3-point linkage with fixed attachment and level compensation.

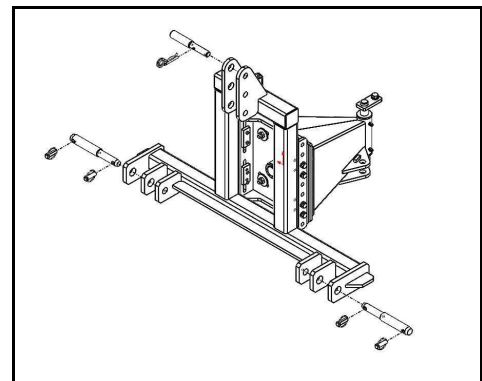

Fig.4.8

Coupling and uncoupling of the attachment

- Height adjustment by moving the bars (1) with screw connections (2).

ATTENTION

Replace self-locking nuts each time they are unscrewed.

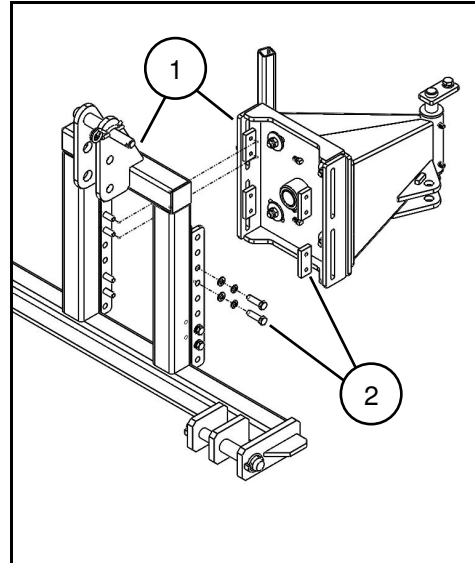

Fig.4.9

- Select bolt diameter (5) or (6) on the draft link hook according to the attachment category of the carrier vehicle:
- Hook and lock the draft link hook rods.
- Use bolts (7) on the upper hook according to the attachment category and lock with the spring plug.

NOTE

Adjust the upper hook so that the attachment receptacle is vertical (90°) to the ground

ATTENTION

Verify the correct seating of the attachment receptacle.

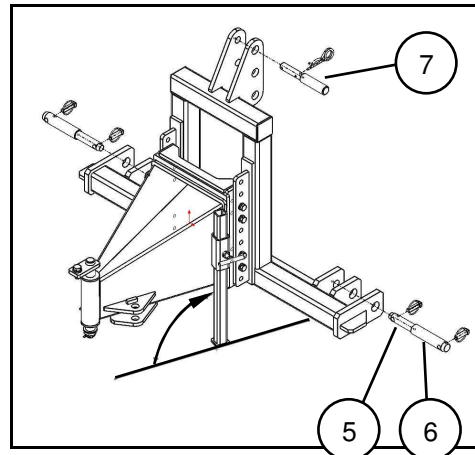

Fig.4.10

- Lift out the attached SK-K snow blade. Loosen locking screws (8). Move the support (9) upward and resecure.
- If present, connect hydraulic hoses and electrical connection line to the carrier vehicle.
- Raise the SK-K snow blade and carry out a functionality check.

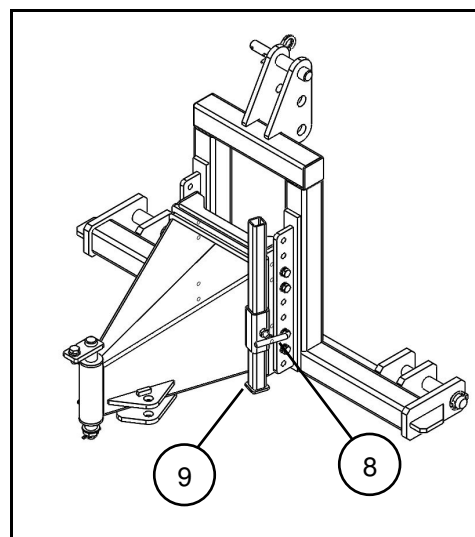

Fig.4.11

4.2.4 Front attachment - coupling triangle



- Observe attachment safety notes listed in chapter 4.2!
- Check the device triangle on the carrier vehicle and on the snow blade for soiling and clean if necessary.
- Check the attachment heights of the device triangles before attaching.

NOTE

Height adjustment by means of screw connection for the device triangle with fixed attachment and level compensation.

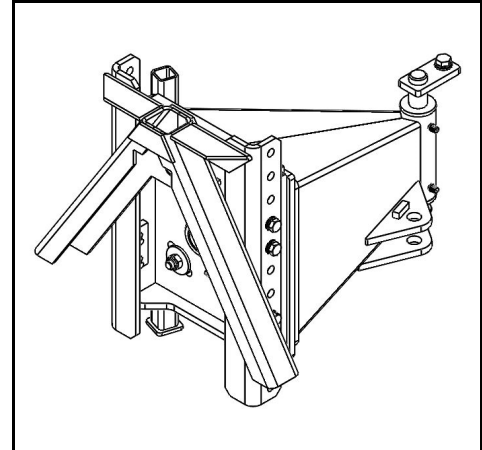

Fig.4.12

- Height adjustment by moving the bars (1) with screw connections (2).

ATTENTION

Replace self-locking nuts each time they are unscrewed.

- Insert the receptacle triangle into the device triangle and lock it.

NOTE

Adjust the locking tongue of the 3-point receptacle on the device triangle of the SK-K snow blade for wear and tear.

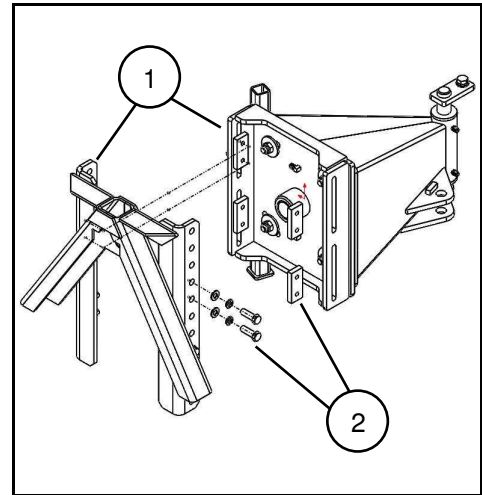

Fig.4.13

Coupling and uncoupling of the attachment

- Loosen countersunk screw (4).
- The locking handle (5) can be moved.
- Loosen locknut (6) on adjustment screw (7) and adjust the locking handle (5).

ATTENTION

Move the locking handle (5) upward until the locking tongue securely reengages in the opposing triangle (8).

- Tightly turn the locknut (6) against the barrel (9).
- Tighten the countersunk screw (4) on the locking handle (5).

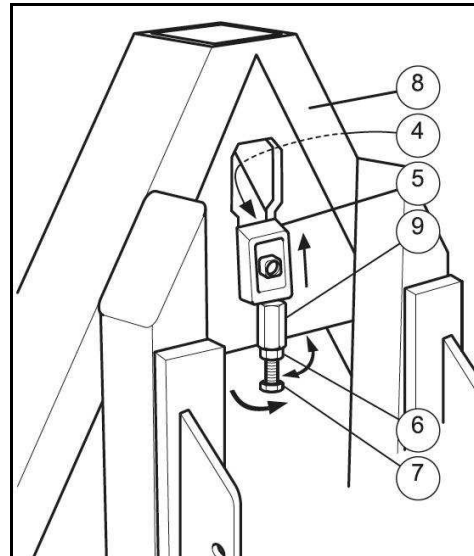

Fig.4.14

- Insert the receptacle triangle into the device triangle and lock it.

ATTENTION

Verify the correct seating of the attachment receptacle.

- Lift out the attached SK-K snow blade, loosen locking screws (10), move the support (11) upward and secure.
- If present, connect hydraulic hoses and electrical connection line to the carrier vehicle.
- Raise the SK-K snow blade and carry out a functionality check.

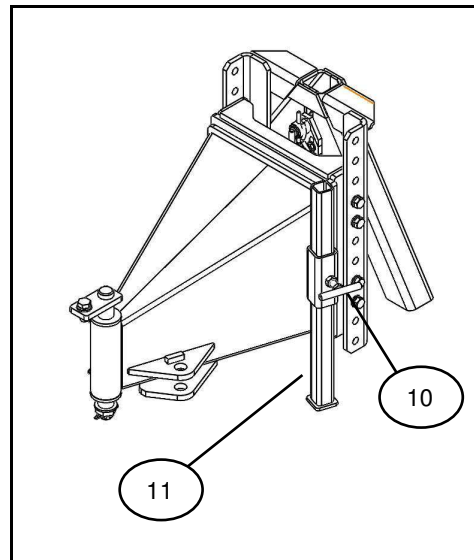

Fig.4.15

4.3 Operation



Contour lights on snow blade required in accordance with StVZO § 53b, if:

- snow blade projects 400 mm sideways beyond the outer edge of the carrier vehicle's contour illumination;
- the outer edge projects more than 1000 mm beyond the rear lights of the vehicle.
- -If the snow blade covers even just part of the headlights, additional headlights must be mounted that adequately illuminate the roadway while in the transport and working position (see also StVZO §50 paragraph 2).

4.4 Transport trips



The safety instructions from Chapter 4.2

Transport trips may only be performed with the SK-K snow blade in the straight position.

(For information on side adjustment, see chapter 4.5.1)

4.4.1 Start-up



The safety instructions from Chapter 4.2 apply



- The operator must have read and understood the operating manual before starting up the attachment.
- The operator must check the machine and attachment for roadworthiness and operational safety before every start-up.
- When starting up the attachment, also pay attention to the notes in chapters:
 - "Operator obligations", on pages 2-3,
 - "Personnel qualification", on pages 2-4
 - "Basic safety notes", on pages 2-7,
 - "Warning notes and instructions", on pages 2-15Observing these chapters is for your own safety.
- Also pay attention to the notes in chapter "Cleaning, servicing and maintenance", on page 7-1.

WARNING



Risk of crushing, shearing, cutting, severing, grabbing, entanglement, pulling in, catching and collisions in the event of operations on the attachment:

- if moving tools are not switched off,
- if hydraulic functions are inadvertently activated, tools or parts of the attachment are operated while the engine of the machine is running,
- if the engine of the machine is started inadvertently,
- if the machine and attachment roll away inadvertently,
- if the raised attachment is lowered inadvertently.

All operations on the attachment are dangerous due to unintentional contact with moving, unsecured tools and the raised, unsecured attachment.

Before performing any operation on the attachment, such as adjustment work or fault remedying, you must:

- safeguard the raised attachment from unintentional lowering,
- turn off the engine of the machine,
- safeguard the machine and the attachment from unintentional start-up and rolling away,
- remove third persons (children) from the machine.

NOTE

Make sure that the support (1) moves upwards and has been secured with the locking screws (2).

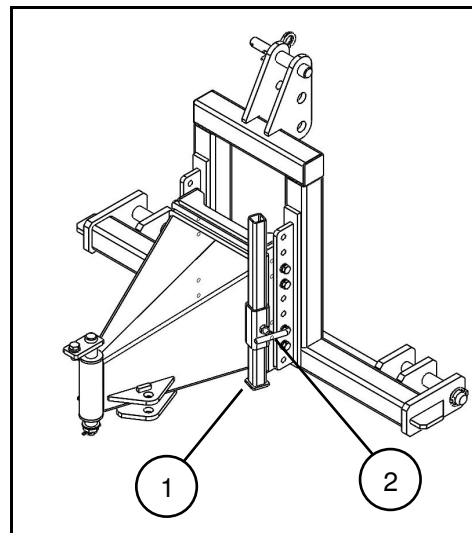

Fig.4.16

- The scraper blade should be at a distance (a) of 5 mm from the ground.
- To adjust, loosen the spring plug (2), adjust to the desired setting.

NOTE

Adjust the support wheels (1) the same on both sides.

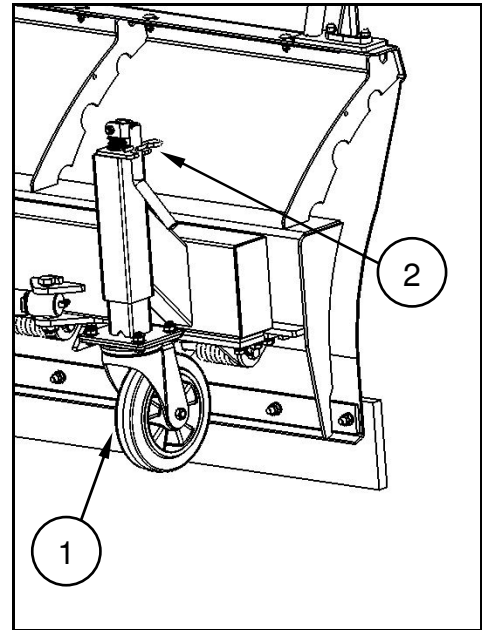

Fig.4.17

4.4.2 Work position for attachment with roller-floating tunnel

- Move the quick change receptacle (1) upward until the support roll carrier (2) can move up and down in the roller-floating tunnel (3).

NOTE

The height indicators with the green caps (4) and (5) are at the same height.

- Vertically align the quick change receptacle (2) until the height indicators (4) and (5) are parallel.

NOTE

When attaching with roller-floating tunnel to the 3-point linkage or coupling triangle, the adjustment of the work position is performed as with the quick change receptacle.

- The maximum travel and clearing speed is 6 km/h. The speed is to be adjusted according to visibility and weather conditions.

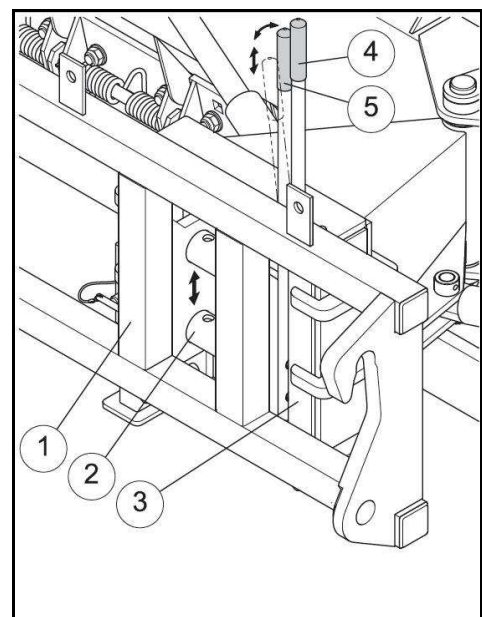

Fig.4.18

4.5 Side adjustment



- Also observe chapter "basic safety notes" page 2-7, for coupling and uncoupling.
- Check the attachment for obvious defects when coupling and uncoupling. Pay attention to the "Operator obligations" chapter, page 2-3 when doing this.

4.5.1 Mechanical side adjustment



The safety instructions from Chapter 4.2 apply
Make adjustments only when attached and raised.
Keep the SK-K snow blade close to the ground.

Mechanical side adjustment

- Pull the spring plug (2) and adjustment bolt (3) out of the outer part (1).
- Swivel the SK-K snow blade 30°.
- In the outer part (1) and inner part (4), secure the position with the adjustment bolt (3) and spring plug (2).

NOTE

If the snow blade hits the carrier vehicle at an angle of 30°, the inner part must be turned.

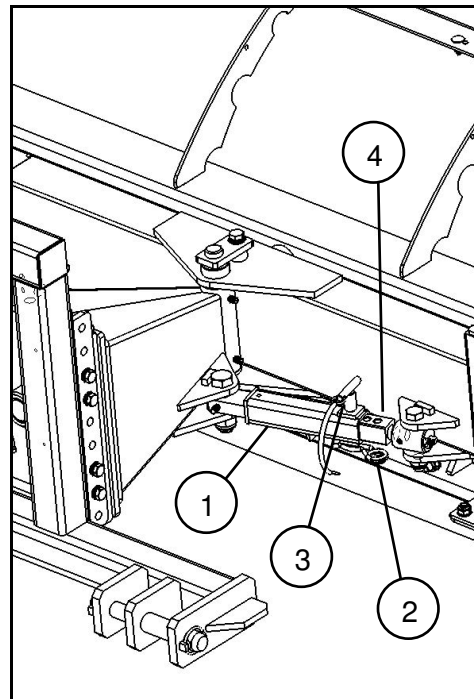

Fig.4.19

4.5.2 Hydraulic side adjustment



The safety instructions from Chapter 4.2 apply

- Danger of getting squashed!

When hydraulically swivelling the snow blade, no persons may be present between the snow blade and the carrier vehicle

ATTENTION

Perform hydraulic side adjustments only while the carrier vehicle is at a standstill.

- Actuate both pitch control cylinders (1) with the appropriate control lever in the carrier vehicle.

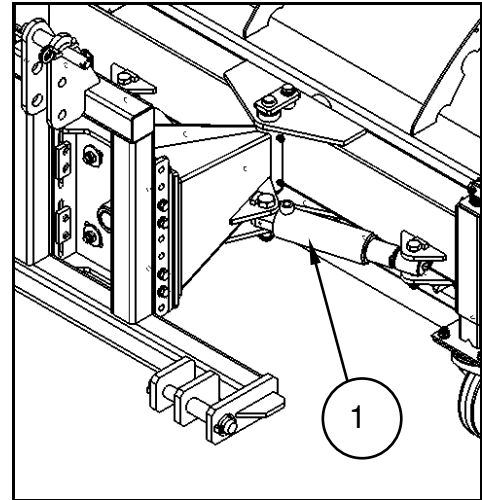

Fig.4.20

4.6 Checking the functionality of the attachment

Always check the functionality of the attachment before initial start-up and before starting work:

1. Couple the attachment to the machine.
2. Lubricate the entire attachment. To do this, see chapter "Cleaning, servicing and maintenance", on page 9-3.
3. Check all functions of the attachment, before it is used for the first time.

4.7 Detaching the SK-K snow blade

WARNING



Risk of crushing and collision for persons can occur if persons are present between the machine and attachment when coupling the attachment!

Remove persons from the hazard area between the machine and the attachment before moving towards the attachment.

Assistants who are present may only act as guides next to the machine and the attachment and may only move between the vehicles when they are at a standstill.

WARNING



Risk of loss of energy supply between machine and attachment due to damaged supply lines!

Pay attention to the routing of the supply lines when they are being connected. The supply lines:

- must give way slightly without any tension, kinking or friction,
- must not chafe against external parts.

WARNING



Risk of crushing, pulling in, catching and collisions for persons if the attachment inadvertently becomes detached from the machine!

- Observe the maximum permitted support, attachment and axle loads of the machine.
- Use and secure the devices provided for connecting the machine and the attachment appropriately.
- Before setting off with the attachment connected, check whether the receptacle is correctly locked.



- Prior to detaching, read and observe the operating manual for the carrier vehicle!
- For figures and terms, see chapter 4.2 on attaching.

Before detaching

- Straighten the SK-K snow blade, see chapter 4.5.1 on side adjustments.



Park the snow blade on a firm and level surface in a dry and clean place.

Accident hazard! Ensure that the snow blade is securely positioned.

- Lower the snow blade until both castor wheels are in contact with the ground.
- The castor wheels must point backward toward the carrier vehicle.
- **Fork arm receptacle:** loosen the clamping T-bolt of the support. Lower the support to the ground and secure.
- Loosen/detach safeguards (chain and clamping T-bolt) in the reverse order of attachment as described in chapter 4.2 on attaching.
- **3-point linkage:** pull out the bolt and spring plug from the support, lower to the ground and secure.
- Loosen the 3-point linkage rod of the carrier vehicle on the 3-point linkage of the snow blade.
- **Coupling triangle:** pull out the bolt and spring plug from the support, lower to the ground and secure.
- Coupling triangle: unlock the lock of the coupling triangle and lower the coupling triangle from the carrier vehicle.
- **Quick change receptacle:** Unlock the receptacle as described in the carrier vehicle's operating manual.
- If present, detach hydraulic lines and electrical line on the carrier vehicle and place on the snow blade.



Accident hazard! Do not place hydraulic hoses and electrical connection lines on the ground as they pose a tripping hazard.

- Drive carrier vehicle backwards.

4.8 Storage



Park the snow blade on a firm and level surface in a dry and clean place. Ensure that the snow blade is in a stable position.

- Park the snow blade so that the support wheels (1) point to the back.
- Loosen the spring plug (2) and adjust support wheel receptacles (3) until the swivel console and the receptacle (5) is perpendicular (90°) to the ground.
- Plug in spring plug (2) again
- Loosen the locking screws (6) on the support, move the support (7) down and resecure.
- For information on detaching, see chapter 6.5



Accident hazard!

Hydraulic hoses and the electrical connection line are a tripping hazard on the ground.

Place the hydraulic hoses and electrical connection line over the snow blade.

ATTENTION

Seal hydraulic connectors with dust caps. Soiling leads to damage on the hydraulic system.

- Clean the snow blade thoroughly. Dirt attracts humidity and leads to the formation of rust.
- Thoroughly grease the snow blade (for lubricating points, see chapter 4.5).
- If necessary, repair paint damage.

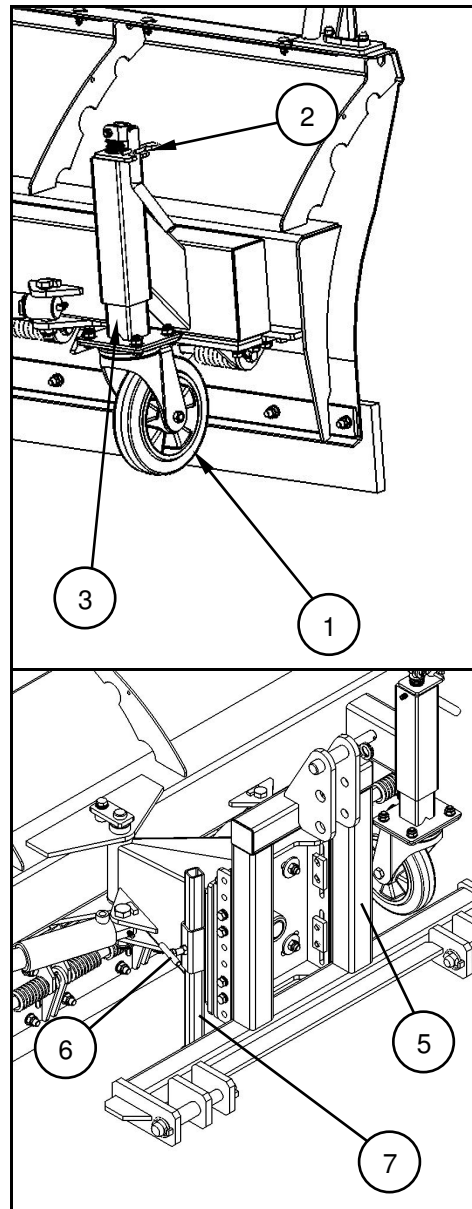

Fig.4.21

5 Hydraulic system

The hydraulic system consists of the following assemblies:

- two single-action hydraulic cylinders.

The hydraulic system is operational when the hydraulic system of the machine is coupled to the hydraulic system of the carrier vehicle.

5.1 Hydraulic lines

WARNING



Risk of infection to persons if hydraulic oil escapes under high pressure and penetrates the body!

Ensure that the hydraulic system of the machine and the attachment is depressurised when coupling and uncoupling the hydraulic lines. Operate all the control levers of the work hydraulics system of the machine several times at both sides.

In the event of injuries caused by hydraulic oil, seek immediate medical attention.

5.1.1 Coupling hydraulic lines

WARNING



Risk of crushing, cutting, grabbing, pulling in and collisions to persons, if the hydraulic lines are connected incorrectly causing malfunctions!

- Note the coloured markings on the hydraulic connectors when coupling the hydraulic lines.
- Check the assignment of the hydraulic lines to the individual hydraulic components on the attachment in case the coloured markings (dust caps) are missing:
 - o P = pressure line
 - o T = return line



- Note the maximum permissible operating pressure of the hydraulic oil of 180 bar.
- Only connect clean hydraulic connectors.
- Make sure that no oil escapes into the surroundings when coupling and uncoupling the hydraulic lines.
- Insert the hydraulic connector into the hydraulic sleeve until the hydraulic connector noticeably locks.
- Check that the connecting points of the hydraulic lines are seated correctly and sealed.
- Coupled hydraulic lines:
 - o must give way slightly when cornering without any tension, kinking or friction,
 - o must not chafe against external parts.

Hydraulic system

1. Apply the parking brake of the machine.
 2. Switch off the engine of the machine and remove the ignition key.
 3. Operate all the control levers of the work hydraulics system of the machine several times at both sides.
- The hydraulic system has been depressurised.
4. Clean the hydraulic connectors of the hydraulic lines before coupling the hydraulic connectors to the hydraulic sleeves.
 5. Couple all of the hydraulic lines of the attachment to the quick-release couplings of the machine:

5.1.2 Uncoupling the hydraulic lines

1. Apply the parking brake of the machine.
 2. Switch off the engine of the machine and remove the ignition key.
 3. Operate all the control levers of the work hydraulics system of the machine several times at both sides.
- The hydraulic system has been depressurised.
4. Release the hydraulic connectors from the hydraulic sleeves.

6 Cleaning, servicing and maintenance



Pay attention to the notes in the chapters below on cleaning, servicing and maintenance:

- "Operator obligations", on pages 2-3,
- "Personnel qualifications", on pages 2-4,
- "Basic safety notes", on pages 2-7,
- "Warning notes and instructions", on pages 2-15.

Observing these chapters is for your own safety.

WARNING



Risk of crushing, shearing, cutting, severing, grabbing, entanglement, pulling in, catching and collisions for persons, if:

- **the raised, unsecured attachment is lowered or lowers inadvertently,**
- **the machine and attachment start up and roll away inadvertently!**
- Safeguard the raised attachment against unintentional lowering before working in the area around it.
- Safeguard the machine and attachment against unintentional start-up and rolling away before cleaning, servicing or maintaining the attachment while it is attached to the machine, see chapter "Safeguard machine and attachment against unintentional start-up and rolling away", page 5-2.
- Wait until the attachment is at a standstill before entering the hazard area of the attachment.

WARNING



Risk of crushing, shearing, cutting, severing, grabbing, entanglement, pulling in and catching for persons if hazardous areas are unprotected!

- Fit the safety equipment which has been removed for cleaning, servicing and maintaining the attachment.
- Replace defective safety equipment with new safety equipment.

WARNING



Dangerous situations may occur if load-bearing parts break due to mechanical work on the frames!

It is strictly forbidden to:

- drill into the frame or chassis,
- drill open existing holes on the frame or chassis,
- perform welding on load-bearing parts.

6.1 Cleaning



- Clean the attachment regularly and thoroughly. Dirt attracts moisture and leads to the build up of rust.
- Lubricate the attachment after cleaning. Avoid moisture when cleaning, blowing off is normally sufficient.
- Pay attention to the legal regulations for handling and removing the cleaning agents.
- Repair any paint damage if necessary.
- Monitor the hydraulic lines extremely carefully!
- Never treat the hydraulic lines with petrol, benzene, petroleum or mineral oil.
- If the attachment cannot be used over a long period of time, the attachment must be lubricated after cleaning, sprayed with oil and the piston rods of the hydraulic cylinder greased.

Cleaning with a high-pressure cleaner / stream jet



- Always observe the following points if a high-pressure cleaner / stream jet is used for cleaning:
- Never direct the cleaning jet of the cleaning nozzle of the high-pressure cleaner / stream jet onto lubricating and bearing points.
 - Always maintain a minimum distance of 300 mm between the high-pressure cleaner and stream jet cleaning nozzle and the attachment.
 - Observe the safety regulations when handling high-pressure cleaners.

6.2 Replacing the scraper bars



- Change the scraper blade only while the snow blade is attached.
- Only perform work on the snow blade with the engine switched off and the hydraulics depressurised. Pull the ignition key and secure the carrier vehicle against unintended start-up and movement.
- Secure the snow blade against lowering!

- Remove locknuts (1) and washers.
- Remove attachment screws (2) with washers and wear bars (3).

NOTE

For Vulkollan wear bars, the clamping bars on the screw side (2) must be dismantled.

- Replace wear bars (3) and mount in the reverse order of removal.

ATTENTION

Replace self-locking nuts each time they are unscrewed.

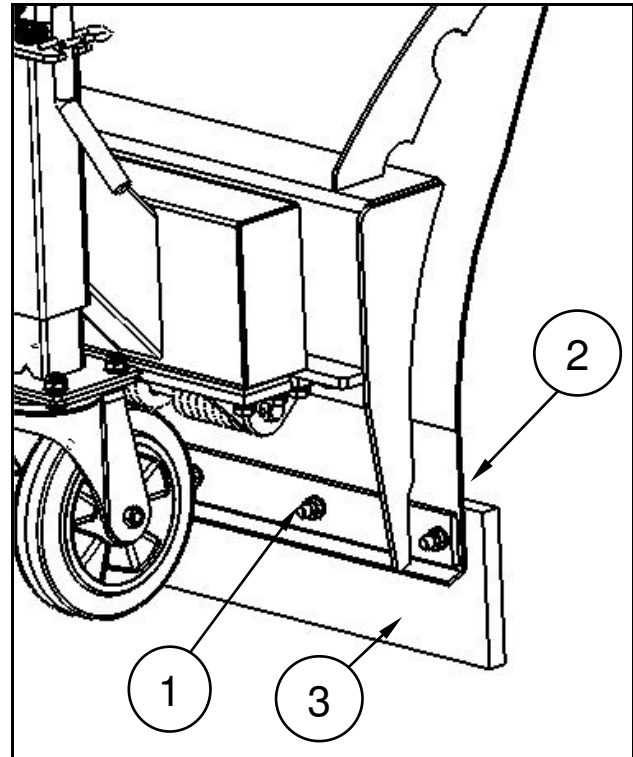

Fig. 6.1

6.3 Replace fuse



The safety instructions from Chapter 2.1 apply.

- Unscrew screw cap (1).
- Replace the fuse.
- Screw on (1) screw cap.

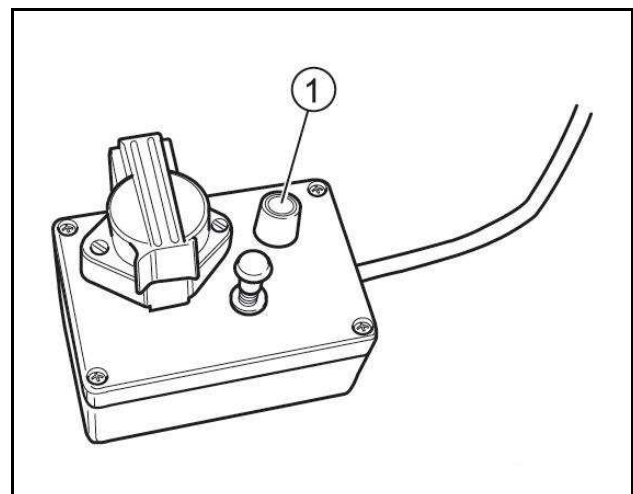

Fig. 6.2

6.4 Lubrication - overview



- Lubricate all bearings and lubricating points according to the lubrication plan.
- Remove dirt from the lubricating nipples.
- Use environmentally-friendly, biodegradable oils and greases in cases where it is possible for lubricants to enter the food chain or the soil. Information can be obtained from your agricultural machinery company.
- Grease the bearings weekly with grease acc. to DIN 51502 (e.g. Gresalit 2 from the Westfalen company)

6.4.1 Lubricating points – snow plough



= grease weekly!

6.4.2 level compensation

- The SK-K snow blade with level compensation has another five lubricating points.
- Refer to the following overview for all other lubricating points!

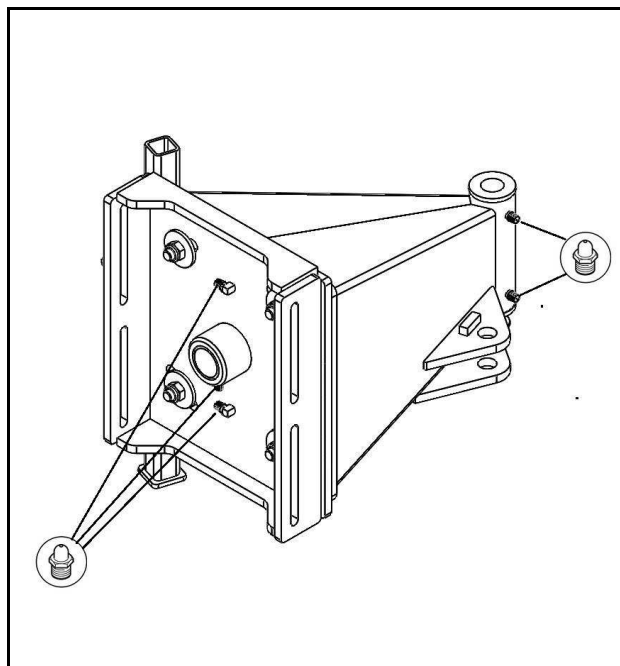
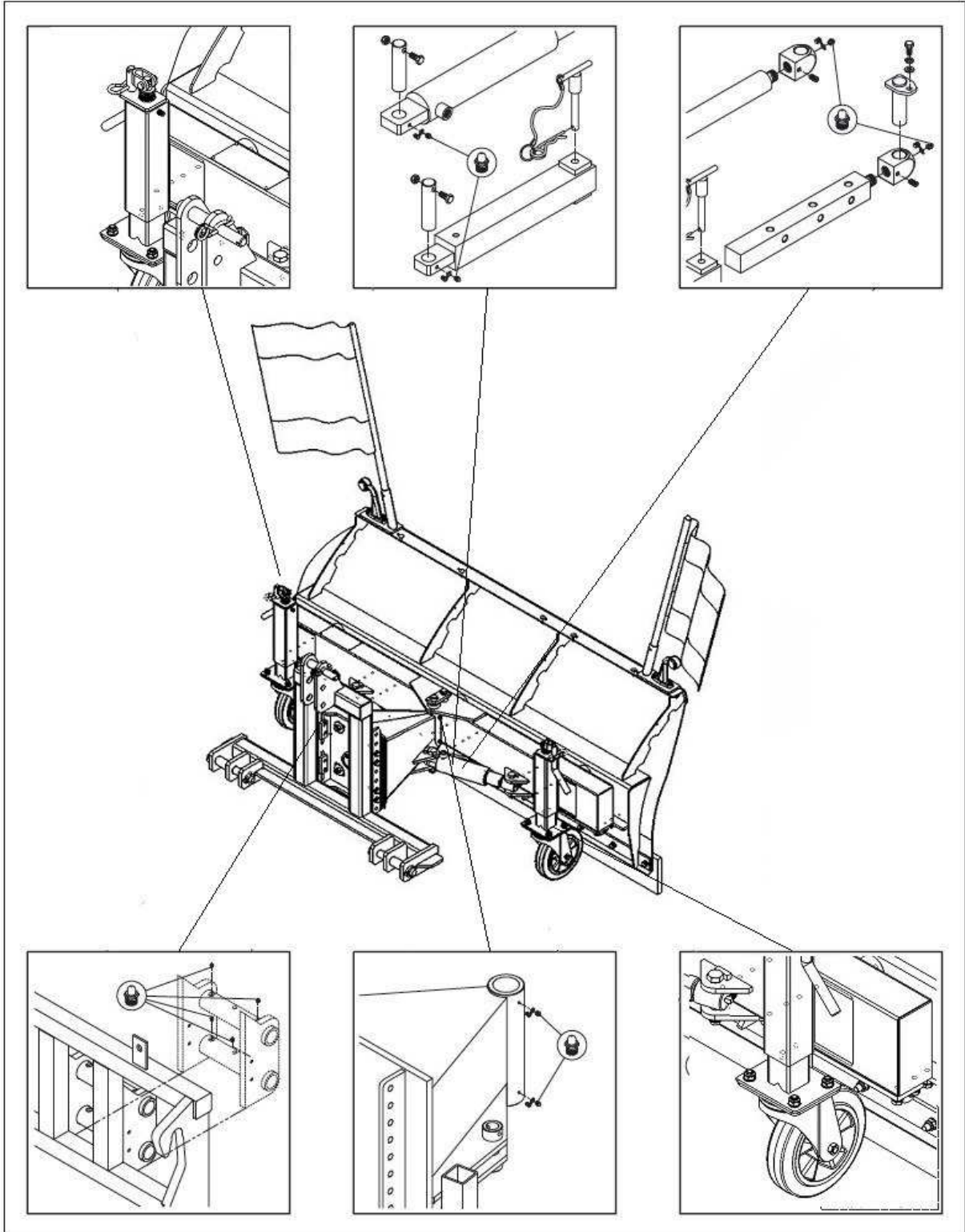

Fig. 6.3

6.4.3 Attachment parts



= grease weekly!



ig. 6.4

6.5 Malfunctions; causes and rectification

Malfunction	Cause	Rectification
1. Hydraulic side adjustment without functionality	<ul style="list-style-type: none"> Hydraulic connections not correct Pressure or volume flow too low Hydraulic cylinder defective 	<ul style="list-style-type: none"> Check connections Ask a qualified workshop Ask a qualified workshop
2. Level compensation does not function	<ul style="list-style-type: none"> Transport lock Insufficient lubrication 	<ul style="list-style-type: none"> Flip the transport lock Grease the five lubricating points on the level compensation
3. Height compensation does not function	<ul style="list-style-type: none"> Roller-guide middle position not achieved 	<ul style="list-style-type: none"> Move green caps of height indicator to same height
4. Clearing results are not satisfactory	<ul style="list-style-type: none"> Height setting of snow blade not correct Attachment plate not perpendicular to ground Scraper blade worn 	<ul style="list-style-type: none"> Check height setting to ground $a = 5 \text{ mm}$ Check setting on carrier vehicle Readjust support wheels, replace scraper blade if necessary
5. Illumination system does not function	<ul style="list-style-type: none"> Electrical connection line not OK Fuse in the cabinet defective Cable break 	<ul style="list-style-type: none"> Check connections Replace fuse Ask a qualified workshop

6.6 Hydraulic system

WARNING



Risk of infection to persons if hydraulic oil escapes under high pressure and penetrates the body!

- Work on the hydraulic system may only be performed by a qualified workshop!
- Make sure the hydraulic system is depressurised, before starting work on the hydraulic system!
- Always use suitable equipment when searching for leaks!
- Never try to seal up leaking hydraulic lines using your hands or fingers.

Liquids (hydraulic oil) escaping under high pressure may penetrate the skin and cause severe injuries!

In the event of injuries caused by hydraulic oil, seek immediate medical attention! Danger of infection!



- Ensure that the hydraulic system of the machine and the attachment is depressurised when connecting the hydraulic lines to the machine's hydraulic system.
- Make sure the hydraulic lines are connected correctly.
- Regularly check all hydraulic lines and couplings for damage and contamination.
- Have the hydraulic lines checked by an expert at least once a year in order to ensure that they are in a safe working condition!
- Replace damaged or aged hydraulic lines! Only use the manufacturer's original hydraulic lines!
- The six year usage duration of the hydraulic must not be exceeded, including a maximum possible storage time of two years.
- Even though they are stored properly and only subjected to the permissible loads, hoses and hose connections are subject to natural ageing, therefore their storage time and usage duration is limited. The usage duration can differ from this in accordance with empirical values, particularly taking the hazard risk into consideration. Different guideline values may apply to hoses and lines made from thermoplastics.
- Dispose of used oil properly. Talk to your oil supplier if you have any problems with disposal!
- Keep hydraulic oil away from children!
- Make sure that no hydraulic oil get into the soil or water!

6.6.1 Labelling of hydraulic lines

The labelling on the valve (Fig.) provides the following information:

- (1) Manufacturer's labelling of the hydraulic line (A1HF)
- (2) Hydraulic line date of manufacture (04 / 02 = year / month = April 2002)
- (3) Maximum permissible operating pressure (210 BAR)

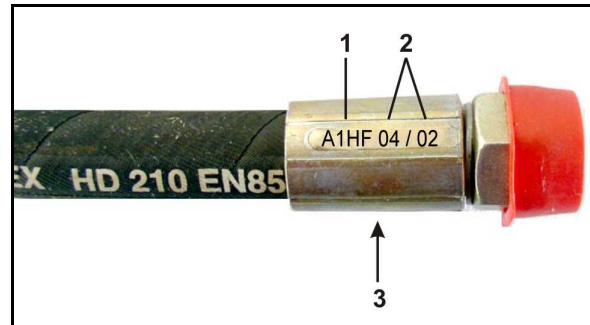

Fig. 6.5

6.6.2 Maintenance intervals

After the first 10 operating hours and then every 50 operating hours:

1. Check all hydraulic system components for tightness.
2. Re-tighten the screw connections if necessary.

Before each start-up:

1. Check the hydraulic lines for obvious defects.
2. Repair chafing points on the hydraulic lines and pipes.
3. Replace worn or damaged hydraulic lines immediately.

6.6.3 Inspection criteria for hydraulic lines



For your own safety:

Replace hydraulic lines immediately, as soon as one of the following defects is noticed:

- Damage to the outer layer up to the insert (e.g. chafing, cuts, cracks).
- Brittleness of the outer layer (visible due to cracks in the hose material).
- Unnatural deformation of the hydraulic line, e.g. delamination, blistering, crushing or kinking.
- Leakage.
- Damage, deformation or leakage of the hose fitting. Minor surface damage is no reason for replacement.
- The hose slipping out of the valve.
- Valve corrosion, which may diminish functionality and strength.
- Improperly routed hydraulic lines, e.g. neglected bending radii, routing across sharp edges.



- The usage duration of 6 years has been exceeded.
The usage duration comes from the date of manufacture of the hydraulic lines plus 6 years.
Example (Fig.): The date of manufacture of the hydraulic lines is stated on the valve, e.g. (07 / 10 = year / month = October 2007). The usage duration therefore ends in October 2013.

6.6.4 Installation and removal of hydraulic lines



Always observe the following notes when installing and removing the hydraulic lines:

- Only use the manufacturer's hydraulic lines.
- Make sure they are clean.
- The hydraulic lines must be installed so that in all operating modes:
 - they are not under tension apart from their own weight,
 - no crushing occurs with short lengths,
 - external mechanical effects on the hydraulic lines are avoided.
 - Prevent the hydraulic lines from chafing on components or on each other by means of proper arrangement and securing. Protect the hydraulic lines with protective covers if necessary. Cover sharp component edges.
 - the permissible bending radii are not undershot.
- the hose length of a hydraulic line must be dimensioned in such a way when connecting to moving parts such that:
 - the smallest permitted bending radius is not undershot over the entire movement range,
 - the hydraulic line is not overstressed.
- Attach the hydraulic line at the intended attachment points. Avoid additional hose brackets which hinder the natural movement and length changes of the hydraulic line.
- Coating of the hydraulic lines is prohibited!

6.7 Screw tightening torques

Thread	Width across flats [mm]	Tightening torques [Nm] in dependence on screw/nut quality		
		8.8	10.9	12.9
M 8	13	25	35	41
M 8x1		27	38	41
M 10	16 (17)	49	69	83
M 10x1		52	73	88
M 12	18 (19)	86	120	145
M 12x1.5		90	125	150
M 14	22	135	190	230
M 14x1.5		150	210	250
M 16	24	210	300	355
M 16x1.5		225	315	380
M 18	27	290	405	485
M 18x1.5		325	460	550
M 20	30	410	580	690
M 20x1.5		460	640	770
M 22	32	550	780	930
M 22x1.5		610	860	1050
M 24	36	710	1000	1200
M 24x2		780	1100	1300
M 27	41	1050	1500	1800
M 27x2		1150	1600	1950
M 30	46	1450	2000	2400
M 30x2		1600	2250	2700

7 Appendix

7.1 Hydraulic circuit diagrams

Hydraulic side adjustment

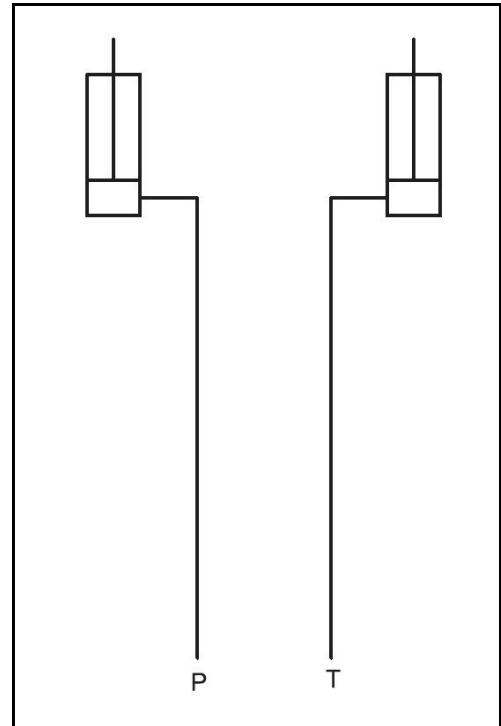

Fig. 7.1

Notes
